

CHAPTER 5A

BUILDING CODE*

*** Editor's Notes:**

1. Pursuant to section 107-28, Hawai'i Revised Statutes ("HRS"), each County shall amend and adopt the Hawai'i State building codes and standards listed in HRS, section 107-25 within two years after adoption by the State Building Code council. If a County does not amend, adopt, and update a State code within this time frame, the respective State code shall become applicable as an interim County code.
2. Chapter 5, "building code" was repealed by ordinance 20-61, section 12, and replaced with Chapter 5A.

Article 1. General Provisions.

- Section 5A-1-1. Title.
- Section 5A-1-2. Purpose.
- Section 5A-1-3. Scope; exceptions.
- Section 5A-1-4. Administrative provisions.
- Section 5A-1-5. Existing buildings.
- Section 5A-1-6. Definitions.
- Section 5A-1-7. Compliance required.
- Section 5A-1-8. Conflict.
- Section 5A-1-9. References to model codes.

Article 2. Installation Requirements.

- Section 5A-2-1. International building code adopted.

Article 3. Adoption, Amendment, and Addition of Appendices.

Division 1. Appendices of International Building Code Adopted.

- Section 5A-3-1. Appendices not applicable.
- Section 5A-3-2. Appendices adopted.
- Section 5A-3-3. Amendments to Appendix C; Group U – agricultural buildings.

Division 2. Appendices Added to the International Building Code.

- Section 5A-3-21. Appendices added to International Building Code.
- Section 5A-3-22. Repealed.
- Section 5A-3-23. Appendix M; Thatch Material on Exterior of Buildings - Protection Against Exposure Fires.
- Section 5A-3-24. Appendix U; Hawai'i Hurricane Sheltering Provisions for New Construction.
- Section 5A-3-25. Appendix W; Hawai'i Wind Design Provisions for New Construction.
- Section 5A-3-26. Appendix X; Indigenous Hawaiian Architecture Structures.
- Section 5A-3-27. Repealed.

Article 4. Building Work Within Special Flood Hazard Areas.

Section 5A-4-1. General applicability.

Section 5A-4-2. Definitions.

Section 5A-4-3. General requirements.

CHAPTER 5
BUILDING
(Rep 2020, ord 20-61, sec 12.)

CHAPTER 5A
BUILDING CODE*

*** Editor's Notes:**

1. Pursuant to section 107-28, Hawai'i Revised Statutes ("HRS"), each County shall amend and adopt the Hawai'i State building codes and standards listed in HRS, section 107-25 within two years after adoption by the State Building Code council. If a County does not amend, adopt, and update a State code within this time frame, the respective State code shall become applicable as an interim County code.
2. Chapter 5, "building code" was repealed by ordinance 20-61, section 12, and replaced with Chapter 5A.

Article 1. General Provisions.

Section 5A-1-1. Title.

This chapter shall be known as the "building code."
(2020, ord 20-61, sec 3.)

Section 5A-1-2. Purpose.

The purpose of this chapter is to provide minimum standards to safeguard life or limb, health, property and public welfare by regulating and controlling the design, construction, quality of materials, use and occupancy, location and maintenance of all buildings and structures within the County and certain equipment specifically regulated herein.
(2020, ord 20-61, sec 3.)

Section 5A-1-3. Scope; exceptions.

This chapter shall apply to the design, construction, alteration, movement, enlargement, replacement, repair, equipment, use and occupancy, location, removal and demolition of buildings or structures or any appurtenances connected or attached to such buildings or structures.

Exception:

Detached one- and two-family dwellings and multiple single-family dwellings and townhouses not more than three stories above *grade plane* in height with a separate means of egress and their *accessory structures* not more than three stories above *grade plane* in height shall be permitted to comply with the residential building code, chapter 5B, Hawai'i County Code if provided with debris impact protection in accordance with Section 1609.2 Protection of Openings. Exception 3 in Section 1609.2 shall not apply.
(2020, ord 20-61, sec 3; am 2021, ord 21-61, sec 14.)

Section 5A-1-4. Administrative provisions.

Provisions relating to permitting, enforcement, inspection, and other administrative procedures pertaining to this chapter are contained in chapter 5, the construction administrative code.
(2020, ord 20-61, sec 3.)

Section 5A-1-5. Existing buildings.

- (a) Permitted buildings in existence at the time of the adoption of this chapter may have their existing permitted use or occupancy continued if such use or occupancy was legal at the time of the adoption of this chapter, provided such continued use does not constitute a hazard to the general safety and welfare of the occupants and the public.
- (b) Alteration, repair, addition, and change of occupancy. Alteration, repair, addition, and change of occupancy to a building or structure in existence at the time of the adoption of this chapter shall comply with the requirements of chapter 34 of the International Building Code, relating to existing structures, until the adoption by the County of the International Existing Building Code.

(2020, ord 20-61, sec 3.)

Section 5A-1-6. Definitions.

As used in this chapter, unless it is apparent from the context that a different meaning is intended:

“Accessory structure” means a structure not greater than 3,000 square feet (279 m²) in floor area, and not over two stories in height, the use of which is customarily accessory to and incidental to that of the dwelling and which is located on the same lot.

“Agricultural building” means a development, including a nonresidential building or structure, built for agricultural or aquacultural purposes, located on a commercial farm or ranch constructed or installed to house farm or ranch implements, agricultural or aquacultural feeds or supplies, livestock, poultry, or other agricultural or aquacultural products, used in or necessary for the operation of the farm or ranch, or for the processing and selling of farm or ranch products. An agricultural building for personal use shall be excluded from this definition.

“Authority having jurisdiction” means the director of the department of public works, or the director’s authorized representative.

“Building work” means the design, construction, alteration, relocation, enlargement, replacement, repair, removal, demolition of any building or structure, or any other activities regulated by this chapter.

“Chapter” means this chapter.

“This code” means the building code, contained in chapter 5A, or the construction administrative code, contained in chapter 5, or both, as the context requires.

“Construction code” means collectively: chapter 5, the construction administrative code; chapter 5A, the building code; chapter 5B, the residential building code; chapter 5C, the existing building code; chapter 5D, the electrical code; chapter 5E, the energy conservation code; chapter 5F, the plumbing code; and all administrative rules adopted pursuant to these chapters.

“Dwelling” means any building that contains one or two dwelling units used, intended, or designed to be built, used, rented, leased, let or hired out to be occupied, or that are occupied for living purposes.

“IBC” means the ICC, International Building Code, 2006 Edition, as copyrighted by the International Code Council, Inc., 4051 West Flossmoor Road, Country Club Hills, IL, 60478-5795.

“ICC” means the International Code Council.

“Owner-builder” means owners or lessees of property who build or improve buildings or structures on their property for their own use, or for use by their immediate family. This definition shall not preempt owner-builder by exemption as defined by section 444-2.5, Hawai‘i Revised Statutes.

“Permit” means a formal authorization issued by the authority having jurisdiction that authorizes performance of specified work, pursuant to the construction code, including the following chapters and all administrative rules adopted pursuant to the following chapters:

- (1) 5, the construction administrative code;
- (2) 5A, the building code;
- (3) 5B, the residential building code;
- (4) 5C, the existing building code;
- (5) 5D, the electrical code;
- (6) 5E, the energy conservation code; and
- (7) 5F, the plumbing code.

“Person” means any individual, firm, partnership, association, or corporation; or its or their successors or assigns, according to the context thereof.

“Section” means a section of a chapter of the International Building Code.

“Table” means a table in this chapter.

(2020, ord 20-61, sec 3; am 2021, ord 21-61, secs 15 and 16.)

Section 5A-1-7. Compliance required.

- (a) No person shall perform or cause to be performed any building work which does not comply with the provisions of this code or any permit issued pursuant to this code.
- (b) No person shall perform any work covered by this code in violation of the provisions of chapters 444 or 448E, Hawai‘i Revised Statutes.
- (c) Any approval or permit issued pursuant to the provisions of this code shall comply with all applicable requirements of this code.
- (d) The granting of a permit, variance, or approval of plans or specifications pursuant to this code does not dispense with the necessity to comply with any applicable law to which a permit holder may also be subject.

(2020, ord 20-61, sec 3.)

Section 5A-1-8. Conflict.

- (a) If any provisions of this code conflict with or contravene provisions of the Hawai'i State Building Code or the International Building Code that have been incorporated by reference, the provisions of this code shall prevail as to all matters and questions arising out of the subject matter of such provisions.
- (b) In situations where two or more provisions of this code and any applicable law, other than those provided for in subsection (a), cover the same subject matter, the stricter shall be complied with.

(2020, ord 20-61, sec 3.)

Section 5A-1-9. References to model codes.

- (1) Wherever referenced in this code, the ICC Electrical Code shall mean the electrical code, chapter 5D, Hawai'i County Code.
- (2) Wherever in this Code reference is made to the International Fuel Gas Code, the provisions of the International Fuel Gas Code shall be deemed to be only guidelines and not mandatory.
- (3) Wherever in this Code reference is made to the International Mechanical Code, the provisions of the International Mechanical Code shall be deemed to be only guidelines and not mandatory.
- (4) Wherever referenced in this code, the International Plumbing Code shall mean the plumbing code, chapter 5F, Hawai'i County Code.
- (5) Wherever in this Code reference is made to the International Property Maintenance Code, the provisions of the International Property Maintenance Code shall be deemed to be only guidelines and not mandatory.
- (6) Wherever referenced in this code, the International Fire Code shall mean the fire code, chapter 26, Hawai'i County Code.
- (7) Wherever referenced in this code, the International Energy Conservation Code, shall mean the energy conservation code, chapter 5E, Hawai'i County Code.

(2020, ord 20-61, sec 3.)

Article 2. Installation Requirements.**Section 5A-2-1. International building code adopted.**

- (a) The International Building Code, 2006 Edition as published by the International Code Council, Incorporated, 4051 West Flossmoor Road, Country Club Hills, IL 60478, including appendices, is incorporated by reference and made a part of this code, subject to any amendments hereinafter set forth in this chapter.

- (b) The scope, technical specifications, and exemptions set forth in the International Building Code, 2006 Edition, are hereby adopted as the standard for building work covered by this code, provided there are no specific provisions in any other section of this code covering the particular matter.
- (c) A copy of the International Building Code, 2006 Edition, shall be available for public inspection at the Hilo and Kailua-Kona offices of the department of public works and at the office of the County clerk.
- (d) The International Building Code, 2006 Edition, adopted and incorporated by reference into this code, shall be subject to the amendments hereinafter set forth.
 - (1) Chapter 1, "Administration," of the International Building Code is deleted in its entirety.
 - (2) Section 202 of the International Building Code is amended by adding the following definitions:

"BUILDING. A building is any structure used or intended for supporting any use or occupancy. The term shall include but not be limited to any structure mounted on wheels such as a trailer, wagon or vehicle which is parked and stationary for any 24-hour period, and is used for business or living purposes; provided, however, that the term shall not include a push cart or push wagon which is readily movable and which does not exceed 25 square feet in area, nor shall the term include a trailer or vehicle, used exclusively for the purpose of selling any commercial product therefrom, which hold a vehicle license and actually travels on public or private streets."

"BUILDING OFFICIAL is the director of the County department of public works or the director's authorized deputy."

"CARPORT is a private garage which is at least 100 percent open on one side and with 50 percent net openings on another side or which is provided with an equivalent of such openings on two or more sides.

A private garage which is 100 percent open on one side and 25 percent open on another side with the latter opening so located to provide adequate cross ventilation may be considered a carport when approved by the building official."

"EXISTING BUILDING is a building for which a legal building permit has been issued, or one which complied with this Code in effect at the time the building was erected."

“FAMILY shall be as defined in the Zoning Code except that a nursing, care home, or other similar facility with not more than five patients may be considered a family under this code.”

“FIRE CODE. The State Fire Code as adopted by the State Fire Council.”

- (3) Section 308.2 of the International Building Code is amended to read as follows:

“**308.2 Group I-1.** This occupancy shall include buildings, structures or parts thereof housing more than 16 persons, on a 24-hour basis, who because of age, mental disability or other reasons, live in a supervised residential environment that provides personal care services in an assisted living facility.

The residents participate in fire drills, are self starting, and may require some physical assistance from up to one staff to reach a point of safety in an emergency situation. Facilities with residents who require assistance by more than one staff member, are not self starting, who are bedridden beyond 14 days, or require intermittent nursing care beyond 45 days, shall reside on the first floor in all Type III, IV, and V construction, or shall be classified as Group I-2.

A facility such as the above with five or fewer persons shall be classified as a Group R-3 or shall comply with the International Residential Code in accordance with Section 101.2. A facility such as above, housing at least six and not more than 16 persons, shall be classified as Group R-4.”

- (4) Section 308.3 of the International Building Code is amended to read as follows:

“**308.3 Group I-2.** This occupancy shall include buildings and structures used for personal, medical, surgical, psychiatric, nursing or custodial care on a 24-hour basis of more than five persons who are not capable of self-preservation. This group shall include, but not be limited to, the following:

Hospitals

Nursing homes (both intermediate-care facilities and skilled nursing facilities)

Mental hospitals

Detoxification facilities

Specialized Alzheimer’s Facilities or areas

Assisted Living Facilities (with residents beyond group I-1 limitations for capability)

A facility such as the above with five or fewer persons shall be classified as Group R-3 or shall comply with the International Residential Code in accordance with Section 101.2.”

- (5) Section 310.1 of the International Building Code is amended to read as follows:

“310.1 Residential Group R. Residential Group R includes, among others, the use of a building or structure, or a portion thereof, for sleeping purposes when not classified as an Institutional Group I or when not regulated by the International Residential Code in accordance with Section 101.2. Residential occupancies shall include the following:

R-1 Residential occupancies where the occupants are primarily transient in nature, including:

- Boarding houses (transient)
- Hotels (transient)
- Motels (transient)

R-2 Residential occupancies containing sleeping units or more than two dwelling units where the occupants are primarily permanent in nature, and facilities providing personal care services that have residents that are capable of self evacuation in an emergency situation, including:

- Apartment houses
- Boarding houses (not transient)
- Convents
- Dormitories
- Facilities providing personal care services (with residents that are capable of self evacuation)
- Fraternities and sororities
- Hotels (nontransient)
- Monasteries
- Motels (nontransient)
- Vacation timeshare properties

Facilities providing personal care services with 16 or fewer occupants are permitted to comply with the construction requirements for Group R-3.

R-3 Residential occupancies where the occupants are primarily permanent in nature and not classified as Group R-1, R-2, R-4 or I including:

- Buildings that do not contain more than two dwelling units.
- Adult facilities that provide accommodations for five or fewer persons of any age for less than 24 hours.
- Child care facilities that provide accommodations for five or fewer persons of any age for less than 24 hours.
- Congregate living facilities with 16 or fewer persons.

Adult and child care facilities that are within a single-family home are permitted to comply with the International Residential Code in accordance with Section 101.2.

R-4 Residential occupancies shall include buildings arranged for occupancy as assisted living facilities including more than five but not more than 16 occupants, excluding staff. Residents shall meet the ability to evacuate requirements and other limitations as required in Group I-1.

Group R-4 occupancies shall meet the requirements for construction as defined for Group R-3, except as otherwise provided for in this code, or shall comply with the International Residential Code.”

- (6) The definition of “Personal Care Service” in Section 310.2 of the International Building Code is amended to read as follows:

“PERSONAL CARE SERVICE. The care of residents who do not require chronic or convalescent, health, medical or nursing care. Personal care involves responsibility for the safety of the resident while inside the building. The types of facilities providing personal care services shall include, but not be limited to, the following: assisted living facilities, residential care facilities, halfway houses, group homes, congregate care facilities, social rehabilitation facilities, alcohol and drug abuse centers and convalescent facilities.”

- (7) The definition of “Residential Care/Assisted Living Facilities” in Section 310.2 of the International Building Code is amended to read as follows:

“ASSISTED LIVING FACILITIES. A building or part thereof housing persons, on a 24-hour basis, who because of age, mental disability or other reasons, live in a supervised residential environment which provides personal care services and are licensed by the State.”

- (8) Section 310.3 of the International Building Code is added as an interim provision until the International Residential Codes are adopted, to read as follows:

“310.3.1 Dwellings and lodging houses. Congregate residences (each accommodating 10 persons or less).

310.3.2 Construction, height and allowable area. Buildings or parts of building classed Group R because of the use or character of the occupancy shall be limited to the types of construction set forth in Table 503 and shall not exceed allowable height as allowed by the IBC.

310.3.3 Location on property. For fire-resistive protection of exterior walls and openings, as determined by location on property, see Section 503, Section 601, Section 704, Section 705 and Section 715 of the IBC.

310.3.4 Access and exit facilities and emergency escapes. Exits shall be provided as specified in Chapter 10.

Access to, and egress from, buildings required to be accessible shall be provided as specified in Chapter 11.

Basements in dwelling units and every sleeping room below the fourth story shall have at least one operable window or door approved for emergency escape or rescue which shall open directly into a public street, public alley, yard or exit court. The units shall be operable from the inside to provide a full clear opening without the use of separate tools.

All escape or rescue windows shall have a minimum net clear openable area of 5.7 square feet. The minimum net clear openable height dimension shall be 24 inches. The minimum net clear openable width dimension shall be 20 inches. When windows are provided as a means of escape or rescue they shall have a finished sill height of not more than 44 inches above the floor.

Bars, grilles, grates or similar devices may be installed on emergency escape or rescue windows or doors, provided:

- (1) The devices are equipped with approved released mechanisms which are operable from the inside without the use of a key or special knowledge or effort; and
- (2) The building is equipped with smoke detectors installed in accordance with Section 310.3.10.

Exceptions:

- (1) Glass jalousie blade windows and fixed glass may be used for emergency escape or rescue.
- (2) Escape or rescue windows in Group R, Division 1 Occupancies opening into an exterior exit balcony serving more than two dwelling units or hotel guest rooms shall have a finished sill height not more than 68 inches above the floor.

310.3.5 Light, ventilation and sanitation.

- (a) **General.** For the purpose of determining the light or ventilation required by this section, any room may be considered as a portion of an adjoining room when half of the area of the common wall is open and unobstructed and provides an opening of not less than one tenth of the floor area of the interior room or 25 square feet, whichever is greater.

Exterior openings for natural light or ventilation required by this section shall open directly onto a public way or a yard or court located on the same lot as the building.

Exceptions:

- (1) Required windows may open into a roofed porch where the porch:
 - (A) Abuts a public way, yard or court; and
 - (B) Has a ceiling height of not less than 7 feet; and
 - (C) Has a longer side at least 65 percent open and unobstructed.
 - (2) Skylights.
- (b) **Light.** Guest rooms and habitable rooms within a dwelling unit or congregate residence shall be provided with natural light by means of exterior glazed opening with an area not less than one tenth of the floor area of such rooms with a minimum of 5 square feet.
- (c) **Ventilation.** Guest rooms and habitable rooms within a dwelling unit or congregate residence shall be provided with natural ventilation by means of an openable exterior opening with an area of not less than one twentieth of the floor area of such rooms with a minimum of 5 square feet.

In lieu of required exterior opening for natural ventilation, a mechanical ventilating system may be provided. Such system

shall be capable of providing two air changes per hour in all guest rooms, dormitories, habitable rooms and in public corridors. One fifth of the air supply shall be taken from the outside.

Bathrooms, water closet compartments, laundry rooms and similar rooms shall be provided with natural ventilation by means of openable exterior openings with an area not less than one twentieth of the floor area of such rooms with a minimum of 1½ square feet.

In lieu of required exterior openings for natural ventilation in bathrooms containing a bathtub or shower or combination thereof, laundry rooms and similar rooms, a mechanical ventilation system connected directly to the outside capable of providing five air changes per hour shall be provided. The point of discharge of exhaust air shall be at least 3 feet from any opening into the building. Bathrooms which contain only a water closet or lavatory or combination thereof, and similar rooms may be ventilated with an approved mechanical recirculating fan or similar device designed to remove odors from the air.

- (d) **Sanitation.** Every building shall be provided with at least one water closet. Hotels or subdivisions thereof where both sexes are accommodated shall contain at least two separate toilet facilities which are conspicuously identified for male or female use, each of which contains at least one water closet. The water closet stool shall be located in a clear space not less than 30 inches in width. The clear space in front of the water closet stool shall not be less than 24 inches.

Dwellings shall be provided with a kitchen equipped with a kitchen sink. Dwelling units, congregate residences and lodging houses shall be provided with a bathroom equipped with facilities consisting of a water closet, lavatory and either a bathtub or shower. Each sink, lavatory and either a bathtub or shower shall be equipped with hot and cold running water necessary for its normal operation.

No dwelling or dwelling unit containing two or more guests rooms shall have room arrangements such that access to a bathroom or water closet compartment intended for use by occupants of more than one sleeping room can be had only by going through another sleeping room, nor shall room arrangements be such that access to a sleeping room can be had only by going through another sleeping room or a bathroom or water closet compartment.

310.3.6 Yards and courts.

- (a) **Scope.** This section shall apply to yards and courts having required windows opening therein.
- (b) **Yards.** Yards shall not be less than 3 feet in width for one-story and two-story buildings. For buildings more than two stories in height, the minimum width of the yard shall be increased at the rate of 1 foot for each additional story. For buildings exceeding 14 stories in height, the required width of the yard shall be computed on the basis of 14 stories.
- (c) **Courts shall not be less than 3 feet in width.** Courts having windows opening on opposite sides shall not be less than 6 feet in width. Courts bounded on three or more sides by the walls of the building shall not be less than 10 feet in length unless bounded on one end by a public way or yard. For buildings more than two stories in height, the court shall be increased 1 foot in width and 2 feet in length for each additional story. For buildings exceeding 14 stories in height, the required dimensions shall be computed on the basis of 14 stories.

Adequate access shall be provided to the bottom of all courts for cleaning purposes. Every court more than two stories in height shall be provided with a horizontal air intake at the bottom not less than 10 square feet in area and leading to the exterior of the building unless abutting a yard or public way. The construction of the air intake shall be as required for the court walls of the building, but in no case shall be less than one-hour fire resistive.

310.3.7 Room dimensions.

- (a) **Ceiling heights.** Habitable space shall have a ceiling height of not less than 7 feet 6 inches except as otherwise permitted in this section. Kitchens, halls, bathrooms and toilet compartments may have a ceiling height of not less than 7 feet measured to the lowest projection from the ceiling. Where exposed beam ceiling members are spaced at less than 48 inches on center, ceiling height shall be measured to the bottom of these members. Where exposed beam ceiling members are spaced at 48 inches or more on center, ceiling height shall be measured to the bottom of the deck supported by these members, provided that the bottom of the members is not less than 7 feet above the floor.

If any room in a building has a sloping ceiling, the prescribed ceiling height for the room is required in only one half the area thereof. No portion of the room measuring less than 5 feet from the finished floor to the finished ceiling shall be included in any computation of the minimum area thereof.

If any room has a furred ceiling, the prescribed ceiling height is required in two thirds the area thereof, but in no case shall the height of the furred ceiling be less than 7 feet.

- (b) **Floor area.** Dwelling units and congregate residences shall have at least one room which shall have not less than 120 square feet of floor area. Other habitable rooms except kitchens shall have an area of not less than 70 square feet. Efficiency dwelling units shall comply with the requirements of Section 310.3.8.
- (c) **Width.** Habitable rooms other than kitchen shall not be less than 7 feet in any dimension.

310.3.8 Efficiency dwellings units. An efficiency dwelling unit shall conform to the requirements of the code except as herein provided:

- (1) The unit shall have a living room of not less than 220 square feet of superficial floor area. An additional 100 square feet of superficial floor area shall be provided for each occupant of such unit in excess of two.
- (2) The unit shall be provided with a separate closet.
- (3) The unit shall be provided with a kitchen sink, cooking appliance and refrigeration facilities, each having a clear working space of not less than 30 inches in front. Light and ventilation conforming to this code shall be provided.
- (4) The unit shall be provided with a separate bathroom containing a water closet, lavatory and bathtub or shower.

310.3.9 Shaft and exit enclosures. Exits shall be enclosed as specified in Section 1020. Elevator shafts, vent shafts, dumbwaiter shafts, clothes chutes and other vertical openings shall be enclosed and the enclosure shall be as specified in Section 707.

310.3.10 Smoke detectors.

- (a) **General.** Dwelling units, congregate residences and hotel or lodging house guest rooms that are used for sleeping purposes shall be provided with smoke detectors. Detectors shall be installed in accordance with the approved manufacturer's instructions.
- (b) **Additions, alterations or repairs to Group R Occupancies.** When the valuation of an addition, alteration or repair to a Group R Occupancy sleeping room exceeds \$1,000 and a permit is required, or when one or more sleeping rooms are added or created in existing Group R Occupancies, smoke detectors shall be installed in accordance with subsections (c), (d), and (e) of this section.
- (c) **Power source.** In new construction, required smoke detectors shall receive their primary power from the building wiring when such wiring is served from a commercial source and shall be equipped with a battery backup. The detector shall emit a signal when the batteries are low. Wiring shall be permanent and without a disconnecting switch other than those required for overcurrent protection. Smoke detectors may be solely battery operated when installed in existing buildings; or in buildings without commercial power; or in buildings which undergo alterations, repairs or additions regulated by subsection (b) of this section.
- (d) **Location within dwelling units.** In dwelling units, a detector shall be installed in each sleeping room and at a point centrally located in the corridor or area giving access to each separate sleeping area. When the dwelling unit has more than one story and in dwellings with basements, a detector shall be installed on each story and in the basement. In dwelling units where a story or basement split into two or more levels, the smoke detector shall be installed on the upper level, except that when the lower level contains a sleeping area, a detector shall be installed on each level. When sleeping rooms are on an upper level, the detector shall be placed at the ceiling of the upper level in close proximity to the stairway. In dwellings units where the ceiling height of a room open to the hallway serving the bedrooms exceeds that of the hallway by 24 inches or more, smoke detectors shall be installed in the hallway and in the adjacent room. Detectors shall sound an alarm audible in all sleeping areas of the dwelling unit in which they are located.

- (e) **Location in efficiency dwelling units, congregate residences and hotels.** In efficiency dwelling units, hotel suites and in hotel and congregate residences sleeping rooms, detectors shall be located on the ceiling or wall of the main room or each sleeping room. When sleeping rooms within an efficiency dwelling unit or hotel suite are on an upper level, the detector shall be placed at the ceiling of the upper level in close proximity to the stairway. When actuated, the detector shall sound an alarm audible within the sleeping area of the dwelling unit, hotel suite or sleeping room in which it is located.

310.3.11 Fire alarm systems. Fire alarm systems shall comply with the Fire Code and be approved by the fire chief.

310.3.12 Cooking unit clearance.

- (a) **Minimum vertical clearance.** There shall be a minimum vertical clearance of not less than 30 inches between the cooking top of domestic oil, gas, and electric ranges and the underside of unprotected combustible material above such ranges. When the underside of such combustible material is protected with insulated millboard of at least $\frac{1}{4}$ inch thick covered with sheet metal of not less than 0.021 inch thick (No 28 U.S. gauge) or a metal ventilating hood, the distance shall be not less than 24 inches.
- (b) **Minimum horizontal clearance.** The minimum horizontal clearance from edge of the burner head(s) of top (or surface) cooking unit to combustible walls extending above the cooking surface shall be not less than 12 inches.

Exception: Walls of combustible materials to be installed within 12 inches of a cooking unit shall be provided with protection equivalent to $\frac{1}{2}$ -inch gypsum wallboard covered with laminated plastic. The height of the laminated plastic shall be 12 inch minimum.

- (c) **Alternate materials.** Where alternate materials other than as specified in subsections (a) and (b) are used as approved by the building official, the surface of such material shall have a smooth nonabsorbent finish.”

- (9) Section 403.8 of the International Building Code is amended to read as follows:

“403.8 Fire command station. Fire command stations shall comply with the Fire Code and be approved by the fire chief.”

- (10) Section 419.4 of the International Building Code is added to read as follows:

“419.4 Group I-1 assisted living facilities. Group I-1 Assisted Living Facilities shall comply with the provisions of Sections 419.4.1 and 419.4.2.

419.4.1 Building story limitations. Buildings shall not exceed one story in Type VB construction, two stories in Types IIB, III, IV, and VA construction, and three stories in Type IIA construction, including any allowable automatic sprinkler increases. Other construction type limitations on stories shall be limited by the provisions of Chapter 5.

4.19.4.2 Group I-1 smoke barriers. Group I-1 occupancies shall be provided with at least one smoke barrier in accordance with Section 709. Smoke barriers shall subdivide every story used by residents for sleeping or treatment into at least two smoke compartments. Each compartment shall have not more than 16 sleeping rooms, and the travel distance from any point in a smoke compartment to a smoke barrier door shall not exceed 150 feet (45,720 mm). At least 10 square feet (0.93 m²) of refuge area per resident shall be provided within the aggregate area of corridors, treatment rooms, or other low hazard common space rooms on each side of each smoke barrier.”

- (11) Section 903.2.5 of the International Building Code is amended to read as follows:

“903.2.5 Group I. An automatic sprinkler system shall be provided throughout buildings with Group I fire area.”

- (12) Section 903.2.7 of the International Building Code is amended to read as follows:

“903.2.7 Group R. An automatic sprinkler system installed in accordance with Section 903.3 shall be provided throughout all buildings with a Group R fire area.

Exception: R-3 residential occupancies.”

(13) Section 911.1 of the International Building Code is amended to read as follows:

“911.1 Features. Where required by other sections of this code, a fire command center for fire department operations shall be provided and shall comply with the Fire Code and be approved by the fire chief.”

(14) Section 1008.2 of the International Building Code is amended to read as follows:

“1008.2 Gates. Gates serving the means of egress system shall comply with the requirements of this section. Gates used as a component in a means of egress shall conform to the applicable requirements for doors.

Exceptions:

- (1) Horizontal sliding or swinging gates exceeding the 4-foot (1219 mm) maximum leaf width limitation are permitted in fences and walls surrounding a stadium.
- (2) Security gates may be permitted across corridors or passageways in school buildings if there is a readily visible durable sign on or adjacent to the gate, stating ‘THIS GATE IS TO REMAIN SECURED IN THE OPEN POSITION WHENEVER THIS BUILDING IS IN USE’. The sign shall be in letters not less than one inch high on a contrasting background. The use of this exception may be revoked by the building official for due cause.”

(15) Chapter 11 of the International Building Code is deleted in its entirety and replaced with the following:

“Chapter 11 - Accessibility

1101 Scope. Buildings or portions of buildings shall be accessible to persons with disabilities in accordance with the following regulations:

- (1) For construction of buildings or facilities of the State and County Governments, compliance with section 103-50, Hawai‘i Revised Statutes, administered by the Disability and Communication Access Board, State of Hawai‘i.
- (2) Americans with Disabilities Act, administered and enforced by the U.S. Department of Justice.
- (3) Fair Housing Act, administered and enforced by the U.S. Department of Housing and Urban Development.

- (4) Other pertinent laws relating to disabilities shall be administered and enforced by agencies responsible for their enforcement.

Prior to the issuance of a building permit, the owner (or the owner's representative, professional architect, or engineer) shall submit a statement that all requirements, relating to accessibility for persons with disabilities, shall be complied with."

- (16) Section 1203.2.2 of the International Building Code is added to read as follows:

"1203.2.2 Unvented attic spaces. The attic space shall be permitted to be unvented when the design professional determines it would be beneficial to eliminate ventilation openings to reduce salt-laden air and maintain relative humidity 60 percent or lower to:

- (1) Avoid corrosion to steel components,
- (2) Avoid moisture condensation in the attic space, or
- (3) Minimize energy consumption for air conditioning or ventilation by maintaining satisfactory space conditions in both the attic and occupied space below."

- (17) Section 1603.3 of the International Building Code is amended to read as follows:

"1603.3 Live loads posted. Where the live loads for which each floor or portion thereof of a commercial or industrial building is or has been designed to exceed 100 psf (4.80 kN/m²), such design live loads shall be conspicuously posted by the owner in that part of each story in which they apply, using durable signs. It shall be unlawful to remove or deface such notices."

- (18) Section 1611.1 of the International Building Code is amended to read as follows:

"1611.1 Design rain loads. Each portion of a roof shall be designed to sustain the load of rainwater that will accumulate on it if the primary drainage system for that portion is blocked plus the uniform load caused by water that rises above the inlet of the secondary drainage system at its design flow. The design rainfall rate shall be based on the 100-year 1-hour rainfall rate indicated in Figure 1611.1 as published by the National Weather Service or on other rainfall rates determined from approved local weather data."

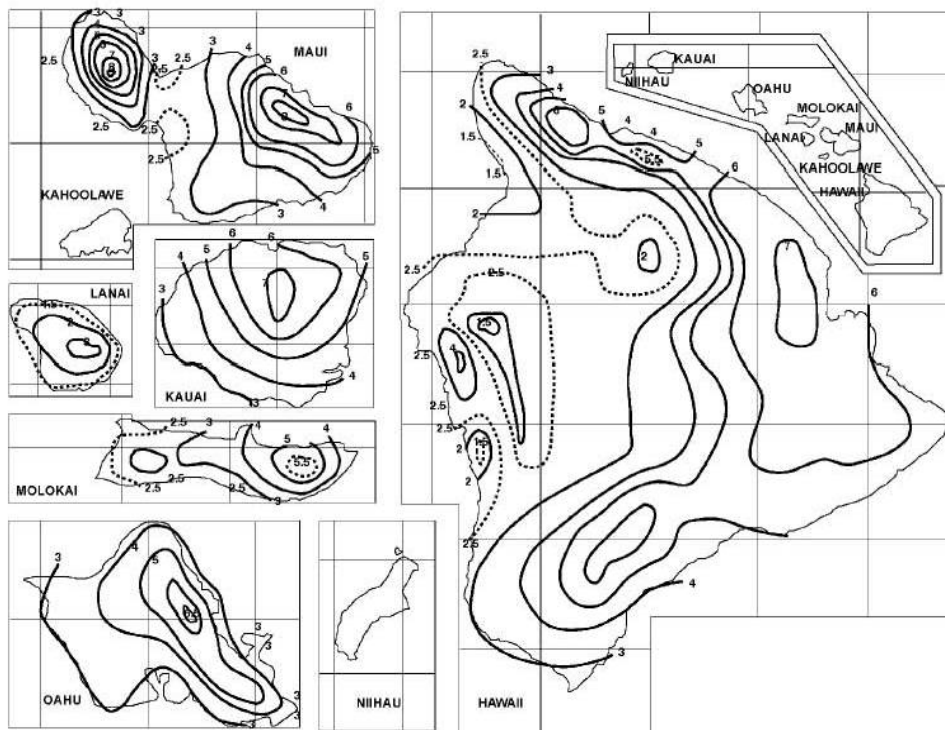

FIGURE 1611.1—continued
100-YEAR, 1-HOUR RAINFALL (INCHES) HAWAII

For SI: 1 inch = 25.4 mm.

Source: National Weather Service, National Oceanic and Atmospheric Administration, Washington D.C.

- (19) Table 1613.5.6(1) in the International Building Code is amended to read as follows:

TABLE 1613.5.6(1)
SEISMIC DESIGN CATEGORY BASED ON
SHORT-PERIOD RESPONSE ACCELERATIONS

| VALUE OF S_{DS} | Occupancy Category | | |
|------------------------------|--------------------|-----|----|
| | I or II | III | IV |
| $S_{DS} < 0.167g$ | A | A | A |
| $0.167g \leq S_{DS} < 0.33g$ | B | B | C |
| $0.33g \leq S_{DS} < 0.50g$ | C | C | D |
| $0.50 \leq S_{DS} < 0.60g$ | C | D | D |
| $0.60g \leq S_{DS}$ | D | D | D |

- (20) Table 1613.5.6(2) in the International Building Code is amended to read as follows:

**TABLE 1613.5.6(2)
SEISMIC DESIGN CATEGORY BASED ON
1-SECOND PERIOD RESPONSE ACCELERATION**

| VALUE OF S_{DI} | Occupancy Category | | |
|-------------------------------|--------------------|-----|----|
| | I or II | III | IV |
| $S_{DI} < 0.067g$ | A | A | A |
| $0.067g \leq S_{DI} < 0.133g$ | B | B | C |
| $0.133g \leq S_{DI} < 0.20g$ | C | C | D |
| $0.20g \leq S_{DI} < 0.25g$ | C | D | D |
| $0.25g \leq S_{DI}$ | D | D | D |

- (21) The definition of “Structural Observation” in Section 1702 of the International Building Code is amended to read as follows:

“STRUCTURAL OBSERVATION. Structural Observation defined in accordance with Hawaii Administrative Rules of the Department of Commerce and Consumer Affairs, Title 16, Chapter 115, implementing Hawaii Revised Statutes chapter 464. Structural observation does not include or waive the responsibility for the inspection required by Section 109, 1704 or other sections of this code.”

- (22) Section 1704.1 of the International Building Code is amended to read as follows:

“1704.1 General. Where application is made for construction as described in this section, the owner or the registered design professional in responsible charge acting as the owner’s agent shall employ one or more special inspectors to provide inspections during construction on the types of work listed under Sections 1704 and 1707. The special inspector shall be a qualified person who shall demonstrate competence, to the satisfaction of the building official, for inspection of the particular type of construction or operation requiring special inspection. These inspections are in addition to the inspections specified in Section 109.

Exceptions:

- (1) Special inspections are not required for work of a minor nature or as warranted by conditions in the jurisdiction as approved by the building official.

- (2) Special inspections are not required for building components unless the design involves the practice of professional engineering or architecture as defined by applicable state statutes and regulations governing the professional registration and certification of engineers or architects.
 - (3) Unless otherwise required by the building official, special inspections are not required for occupancies in Group R-3 as applicable in Section 101.2 and occupancies in Group U that are accessory to a residential occupancy including, but not limited to, those listed in Section 312.1.”
- (23) Section 1704.1.1 of the International Building Code is amended to read as follows:
- “**1704.1.1 Statement of special inspections.** The construction drawings shall include a complete list of special inspections required by this section.”
- (24) Section 1704.1.2 of the International Building Code is amended to read as follows:
- “**1704.1.2 Report requirement.** Special inspectors shall keep records of inspections. The special inspector shall furnish inspection reports to the owner, and licensed engineer or architect of record. Reports shall indicate that work inspected was done in conformance to approved construction documents. Discrepancies shall be brought to the immediate attention of the contractor for correction, then, if uncorrected, to the licensed engineer or architect of record and to the building official. The special inspector shall submit a final signed report to the owner and licensed engineer or architect of record, stating whether the work requiring special inspection was, to the best of the inspector’s knowledge, in conformance to the approved plans and specifications and the applicable workmanship provisions of this code. Prior to the final inspection required under Section 109.3.10, the licensed engineer or architect of record shall submit a written statement verifying receipt of the final special inspection reports and documenting that there are no known unresolved code requirements that create significant public safety deficiencies.”
- (25) Section 1705 of the International Building Code is deleted in its entirety.

(26) Section 1709 of the International Building Code is amended to read as follows:

“1709 Structural observations. Structural observations shall be performed in accordance with Hawai‘i Revised Statutes, chapter 464, section 5, administered and enforced by the department of commerce and consumer affairs.”

(27) Section 1808.2.7 of the International Building Code is amended to read as follows:

“1808.2.7 Splices. Splices shall be constructed so as to provide and maintain true alignment and position of the component parts of the pier or pile during installation and subsequent thereto and shall be of adequate strength to transmit the vertical and lateral loads and moments occurring at the location of the splice during driving and under service loading. Splices occurring in the upper 10 feet (3048 mm) of the embedded portion of the pier or pile shall be capable of resisting at allowable working stresses the moment and shear that would result from an assumed eccentricity of the pier or pile load of 3 inches (76 mm), or the pier or pile shall be braced in accordance with Section 1808.2.5 to other piers or piles that do not have splices in the upper 10 feet (3048 mm) of embedment.”

(28) Section 2104.1.9 of the International Building Code is added to read as follows:

“2104.1.9 Cleanouts. Cleanouts shall be provided for all grout pours over 5 feet 4 inches in height. Special provisions shall be made to keep the bottom and sides of the grout spaces, as well as the minimum total clear area required by ACI 530.1-05/ASCE 6-05/TMS 602-05 clean and clear prior to grouting.

Exception: Cleanouts are not required for grout pours 8 feet or less in height providing all of the following conditions are met:

- (1) The hollow masonry unit is 8-inch nominal width or greater with specified compressive strength f_m less than or equal to 1,500 psi;
- (2) Fine grout is used complying with ASTM C-476 minimum compressive strength of 2,500 psi; and
- (3) Special Inspection is provided.”

- (29) Section 2303.1.8 of the International Building Code is repealed and replaced in its entirety to read as follows:

“2303.1.8 Preservative-treated wood. Structural lumber, including plywood, posts, beams, rafters, joists, trusses, studs, plates, sills, sleepers, roof and floor sheathing, flooring and headers of new wood-frame buildings and additions shall be:

- (1) Treated in accordance with AWPA Standard U1 (UC1 thru UC4B) for AWPA Standardized Preservatives, all marked or branded and monitored by an approving agency. Incising is not required, providing that the retention and penetration requirements of these standards are met.
- (2) For SBX disodium octaborate tetrahydrate (DOT), retention shall be not less than 0.28 pcf B_2O_3 (0.42 pcf DOT) for exposure to Formosan termites. All such lumber shall be protected from direct weather exposure as directed in AWPA UC1 and UC2.
- (3) For structural glued-laminated members made up of dimensional lumber, engineered wood products, or structural composite lumber, pressure treated in accordance with AWPA U1 (UC1 thru UC4B) or by Light Oil Solvent Preservative (LOSP) treatment standard as approved by the building official. Water based treatment processes as listed in paragraphs 1 and 2 are not allowed to be used on these products unless specified by a structural engineer for use with reduced load values and permitted by the product manufacturer.
- (4) For structural composite wood products, treated by non-pressure processes in accordance with AWPA Standard U1 (UC1, UC2 and UC3A) or approved by the building official.

2303.1.8.1 Treatment. Wood treatment shall include the following:

- (1) A quality control and inspection program which meets or exceeds the current requirements of AWPA Standards M2-01 and M3-03;
- (2) Inspection and testing for the treatment standards as adopted by this code shall be by an independent agency approved by the building official, accredited by the American Lumber Standards Committee (ALSC) and contracted by the treating company;
- (3) Field protection of all cut surfaces with a preservative, which shall be applied in accordance with AWPA Standard M-4-02 or in accordance with the approved preservative manufacturer's ICC-Evaluation Services report requirements.

2303.1.8.2 Labeling. Labeling shall be applied to all structural lumber 2 inches or greater nominal thickness, with the following information provided on each piece as a permanent ink stamp on one face or on a durable tag permanently fastened to ends with the following information:

- (1) Name of treating facility;
- (2) Type of preservative;
- (3) AWWPA use category;
- (4) Quality mark of third party inspection agency;
- (5) Retention minimum requirements; and
- (6) Year of treatment.

All lumber less than 2 inches in nominal thickness, shall be identified per bundle by means of a label consisting of the above requirements. Labels measuring no less than 6 inches by 8 inches shall be placed on the lower left corner of the strapped bundle.

2303.1.8.3 Moisture content of treated wood. When wood pressure treated with a water-borne preservative is used in enclosed locations where drying in service cannot readily occur, such wood shall be at a moisture content of 19 percent or less before being covered with insulation, interior wall finish, floor covering or other material.”

- (30) Section 2304.9.5 of the International Building Code is amended to read as follows:

“2304.9.5 Fasteners in non-borate-preservative-treated and fire-retardant-treated wood. Fasteners for preservative-treated and fire-retardant-treated wood, other than Borate (SBX, ZB) or LSOP treatments as approved in Section 2303.1.8 Preservative-Treated Wood, shall be of hot dipped zinc-coated galvanized steel, stainless steel, silicone bronze or copper. The coating weights for zinc-coated fasteners shall be in accordance with ASTM A 153.

Exception: Fasteners other than nails, timber rivets, wood screws and lag screws shall be permitted to be of mechanically deposited zinc-coated steel with coating weights in accordance with ASTM B 695, Class 55 minimum.

Fastenings for wood foundations shall be as required in AF&PA Technical Report No. 7.”

- (31) Section 2304.11 of the International Building Code is amended to read as follows:

“2304.11 Protection against decay and termites.

2304.11.1 General. Where required by this section, protection from decay and termites shall be provided by the use of naturally durable or preservative-treated wood.

2304.11.2 Wood used above ground. Structural lumber installed above ground shall be preservative-treated wood in accordance with Section 2303.1.8.

2304.11.2.1 Soil treatment and termite barriers. Where structural lumber of wood frame buildings or structures are supported directly on the ground by a concrete slab, or concrete and/or masonry foundation Formosan subterranean termite protection shall be provided by either chemically treating the soil beneath and adjacent to the building or structure by a Hawai'i licensed pest control operator, or stainless steel termite barrier, or other termite protection measures approved by the Building Official.

All soil treatment, stainless steel termite barrier, and termite protection measures shall be installed according to manufacturer's recommendations for control of Formosan subterranean termites.

2304.11.3 Wood in ground contact. Wood supporting permanent buildings and structures, which is in direct soil contact or is embedded in concrete or masonry in direct contact with earth shall be treated to the appropriate commodity specification of AWPA Standard U1.

Wood in direct soil contact but not supporting any permanent buildings or structures shall be treated to the appropriate commodity specification of AWPA Standard U1 for ground contact.

2304.11.4 Retaining walls. Wood in retaining or crib wall shall be treated to AWPA Standard U1.

2304.11.5 Wood and earth separation. Where wood is used with less than 6-inch vertical separation from earth (finish grade), it shall be treated for ground-contact use.

Where planter boxes are installed adjacent to wood frame walls, a 2-inch-wide (51 mm) air space shall be provided between the planter and the wall. Flashings shall be installed when the air space is less than 6 inches (152 mm) in width. Where flashing is used, provisions shall be made to permit circulation of air in the air space. The wood-frame wall shall be provided with an exterior wall covering conforming to the provisions of Section 2304.6.

2304.11.6 Under-floor clearance for access and inspection.

Minimum clearance between the bottom of floor joists or bottom of floors without joists and the ground beneath shall be 24 inches; the minimum clearance between the bottom of girders and the ground beneath shall be 18 inches.

Exception: Open slat wood decks shall have ground clearance of at least 6 inches for any wood member.

Accessible under-floor areas shall be provided with a minimum 18 inch-by 24 inch access opening, effectively screened or covered. Pipes, ducts and other construction shall not interfere with the accessibility to or within under-floor areas.

2304.11.7 Wood used in retaining walls and cribs. Wood installed in retaining or crib walls shall be preservative treated in accordance with AWWPA U1 (Commodity Specifications A or F) for soil and fresh water use.

2304.11.8 Weather exposure. All portions of timbers (over 5-inch nominal width) and glued-laminated timbers that form structural supports of a building or other structure shall be protected by a roof, eave, overhangs, flashings, or similar coverings.

All wood or wood composite panels, in weather-exposed applications, shall be of exterior type.

2304.11.9 Water splash. Where wood-frame walls and partitions are covered on the interior with plaster, tile or similar materials and are subject to water splash, the framing shall be protected with approved waterproof paper conforming to section 1404.2.

2304.11.10 Pipe and other penetrations. Insulations around plumbing pipes shall not pass through ground floor slabs. Openings around pipes or similar penetrations in a concrete or masonry slab, which is in direct contact with earth, shall be filled with non-shrink grout, BTB, or other approved physical barrier.”

- (32) Section 2308.1 of the International Building Code is amended to read as follows:

“2308.1 General. The requirements of this section are intended for conventional light-frame construction. Other methods are permitted to be used, provided a satisfactory design is submitted showing compliance with other provisions of this code. Interior nonload-bearing partitions, ceilings and curtain walls of conventional light-frame construction are not subject to the limitations of this section. Alternatively, compliance with AF&PA WFCM shall be permitted subject to the limitations therein and the limitations of this code.”

- (33) Section 2701.1 of the International Building Code is amended to read as follows:

“2701.1 Scope. This chapter governs the electrical components, equipment and systems used in buildings and structures covered by this code. Electrical components, equipment and systems shall be designed and constructed in accordance with the provisions of the National Electrical Code, NFPA 70.”

- (34) Section 2901.1 of the International Building Code is amended to read as follows:

“2901.1 Scope. The provisions of this chapter and the Uniform Plumbing Code shall govern the erection, installation, alteration, repairs, relocation, replacement, addition to, use or maintenance of plumbing equipment and systems. Plumbing systems and equipment shall be constructed, installed and maintained in accordance with the Uniform Plumbing Code and adopted amendments. Private sewage disposal systems shall conform to the International Private Sewage Disposal Code.”

- (35) Section 3001.1 of the International Building Code is amended to read as follows:

“3001.1 Scope. This chapter shall be a guideline and governs the design, construction, installation, alteration and repair of elevators and conveying systems and their components. If this chapter conflicts with another applicable law of the jurisdiction, then said applicable law shall prevail over this chapter.”

- (36) Section 3109.3 of the International Building Code is amended to read as follows:

“3109.3 Public swimming pools. Public swimming pools shall be completely enclosed by a fence at least 4 feet (1219 mm) in height or a screen enclosure. Openings in the fence shall not permit the passage of a 4-inch-diameter (102 mm) sphere. The fence or screen enclosure shall be equipped with self-closing and self-latching gates.

Exception: Swimming, dipping, or wading pools located on the premises of a hotel are not required to be enclosed.”

- (37) Section 3405.1 of the International Building Code is amended to read as follows:

“3405.1 Conformance. The installation or replacement of glass shall be as required by Chapter 24 for new installations.”

- (38) Section 3410.3.2 of the International Building Code is amended to read as follows:

“3410.3.2 Compliance with other codes. Buildings that are evaluated in accordance with this section shall comply with the State Fire Code.”

(2020, ord 20-61, sec 3.)

Article 3. Adoption, Amendment, and Addition of Appendices.

Division 1. Appendices of International Building Code Adopted.

Section 5A-3-1. Appendices not applicable.

Provisions in the appendices of the International Building Code, 2006 Edition, shall not apply unless specifically adopted.

(2020, ord 20-61, sec 3.)

Section 5A-3-2. Appendices adopted.

The following appendices of the IBC are hereby adopted and incorporated by reference herein and made a part of this code, subject to the amendments hereinafter set forth in this article:

- (1) Appendix C, Group U-Agricultural Buildings; and
- (2) Appendix I, Patio Covers.

(2020, ord 20-61, sec 3.)

Section 5A-3-3. Amendments to Appendix C; Group U – agricultural buildings.

Section C101, General, is amended by adding the following:

“C101.2 Horticulture buildings. Buildings and structures of Group U Occupancy for horticultural use with covering of wire screen, cheesecloth, or non-rigid plastic sheets are not required to conform to the requirements of Chapters 4-9, 11-26, 28, 30, 31, 34 and 35 of this code when located in areas zoned for agricultural use and not part of any other structure.

C101.3 Fences.

C101.3.1 General. Fences shall be constructed in accordance with this code and all applicable County and State regulations.

C101.3.2 Barbed or razor wire fences. Barbed or razor wire shall not be used for construction of any fence.

Exceptions:

- (a) Barbed or razor wire may be used in fences enclosing the following premises, provided that barbed or razor wire shall be placed along or above the height of 6 feet from the ground, subject to the approval of the fire department:
 - (1) Any “public utility” as defined in section 269-1, Hawai‘i Revised Statutes;
 - (2) Premises in industrial zoned districts and used for storage or handling of hazardous materials, and premises zoned I-2 or I-3, intensive or waterfront industrial districts which are used for industrial purposes and are not adjacent to premises used for other purposes;
 - (3) Zoos for keeping animals and birds for public view or exhibition;
 - (4) Jails, prisons, reformatories, and other institutions which are involved in law enforcement or military activities where security against entry is an important factor.
- (b) Barbed wire may be used in premises used for pasturing livestock, including but not limited to: horses; cattle; sheep; goats; camelids; and pigs, or to keep wild animals out.

Section C101.3.3 Construction barrier. See Section 3306 for fences allowed during construction or demolition.”

(2020, ord 20-61, sec 3.)

Division 2. Appendices Added to the International Building Code.

Section 5A-3-21. Appendices added to International Building Code.

The following appendices are hereby added to the International Building Code and made a part of this code, as set forth in full in this article:

- (1) Appendix M, Thatch Material on Exterior of Buildings – Protection Against Exposure Fires;
 - (2) Appendix U, Hawai'i Hurricane Sheltering Provisions for New Construction;
 - (3) Appendix W, Hawai'i Wind Design Provisions for New Construction;
 - (4) Appendix X, Indigenous Hawaiian Architecture Structures.
- (2020, ord 20-61, sec 3; am 2021, ord 21-61, sec 17.)

Section 5A-3-22. Repealed.

(2020, ord 20-61, sec 3; rep 2021, ord 21-61, sec 18.)

BUILDING CODE

This page intentionally left blank.

HAWAII COUNTY CODE

This page intentionally left blank.

Section 5A-3-23. Appendix M; Thatch Material on Exterior of Buildings - Protection Against Exposure Fires.

Appendix M is added to read as follows:

**“APPENDIX M
THATCH MATERIAL ON EXTERIOR OF BUILDINGS; PROTECTION
AGAINST EXPOSURE FIRES**

**SECTION M101
GENERAL**

M101.1 General. Thatched materials used on the roof on a building shall be protected by manually operated sprinkler heads, with adequate water supply, pipe size, and sprinkler head spacing in accordance with sprinkler system requirements set forth in this section.

Thatched materials used on the wall of a building shall be protected by manually operated outside sprinklers. Size and spacing of sprinklers and pipe size shall be in accordance with Chapter 7, “Outside Sprinklers and Protection Against Exposure Fires,” of the National Fire Codes of the National Fire Protection Association. Controls shall be set forth in this section.

**SECTION M102
APPLICABILITY**

M102.1 Applicability. Thatched material on the exterior of buildings shall be permitted only upon buildings located in areas zone for resort (V Resort-Hotel by the Planning Department) uses which primarily service the tourist trade when approved by the building official.

The thatched material permitted in this section shall be used for decorative purposes on the roof or wall of buildings. The building, independent of the thatched material, shall comply with all applicable provisions of this appendix.

When thatched material is used as permitted in this section, and an appropriate permit is obtained therefore, outside sprinklers for protection against exposure fires shall be required as hereinafter provided.

**SECTION M103
SPRINKLER**

M103.1 General. Sprinklers shall be located at the high point of the roof. Upright or pendant sprinklers shall be used for gable roofs. Sidewall sprinklers shall be used for shed roofs.

M103.2 Spacing of sprinklers. The maximum width of roof with one row of sprinklers shall be as follows:

| Roof Slope | Orifice Size (In inches) | Width of Roof |
|-------------------|-------------------------------------|----------------------|
| 1:3 or greater | 3/8 | 15' |
| 1:3 or greater | 1/2 | 20' |
| 1:3 or greater | 17/32 | 25' |
| Less than 1:3 | 3/8 | 10' |
| Less than 1:3 | 1/2 | 15' |
| Less than 1:3 | 17/32 | 20' |

Maximum spacing of sprinklers on branch lines (along ridge) shall be as follows: 3/8- inch orifice – 6 feet; 1/2-inch orifice – 8 feet; 17/32-inch orifice – 10 feet.

Conical roofs may be protected with one sprinkler at the apex if the diameter of the roof does not exceed the width of roof referred to in this section.

Where the width of a roof exceeds the width allowed for one row of sprinklers, as provided in the table in this section, two or more rows of sprinklers shall be required. The rows of sprinklers shall be placed such that the entire roof area is protected.

M103.3 Areas protected. Each area (zone) of thatched material that is separated from another thatched area by an open space of 20 feet or more or by incombustible construction of 20 feet or more shall be considered a separate area (zone).

Risers to each separate zone shall not be less than that shown in subsection M103.5, Riser and pipe size, except as modified as follows:

- (1) More than one zone may be protected by one valve, if the supply is adequate.
- (2) If one area (zone) is larger than can be protected with the existing supply, the zones can be subdivided into subzones if the following criteria are met: An area of at least 800 square feet is protected by the subzone control valve; there is at least a 10 percent overlap in coverage of adjoining subzones; and operation of the manual control valves will automatically transmit an alarm to the fire department.

M103.4 Water supply. The sprinkling system shall have a separate connection to the water main in the street, to an approved automatic fire-extinguishing system supply line, to a wet standpipe supply line, or to a domestic supply of adequate size. The water supply required shall be determined from either of the following:

- (1) Flow per sprinkler for the largest zone, with residual pressure at the highest sprinkler at 15 pounds per square inch with all heads operating, shall be as follows:

| Orifice Size (In inches) | Gallons Per Minute |
|-----------------------------|--------------------|
| 3/8 | 15 |
| 1/2 | 20 |
| 17/32 | 25 |

- (2) The flow shall be hydraulically calculated so as to discharge at least 0.11 gallons per minute per square foot of surface area to be sprinkled.

M103.5 Riser and pipe size. Pipe sizes shall be determined from the flow as calculated in subsection M103.4, Water supply. However, no pipe less than one inch in size shall be used. The following table may be used in conjunction with this flow calculated for the selection of pipe or riser sizes.

| Orifice Size (In inches) | Pipe or Riser Size (In inches) | | | | | | | |
|--------------------------|--------------------------------|-------|-------|----|-------|----|-------|----|
| | 1 | 1-1/4 | 1-1/2 | 2 | 2-1/2 | 3 | 3-1/2 | 4 |
| | No. of Sprinklers | | | | | | | |
| 3/8 | 3 | 4 | 7 | 11 | 21 | 37 | 40 | 40 |
| 1/2 | 2 | 3 | 5 | 8 | 15 | 27 | 40 | 40 |
| 17/32 | 1 | 2 | 4 | 6 | 11 | 19 | 30 | 38 |

M103.6 Number of sprinklers served. The number of sprinklers on a branch line shall not exceed six. Center feet shall be used for six or more sprinklers. The number of sprinklers under control of each control valve shall not exceed forty. At the location of each valve, there shall be a drain connection and a 1/4-inch valve test connection to accommodate pressure gauge.

M103.7 Material installed above grade. Piping shall be galvanized steel schedule 40 with galvanized malleable iron fittings or hard drawn copper with silver solder fittings. Pipes shall be securely fastened to the structure.

Valves shall be manual type approved and listed by the Underwriters' Laboratories or by other approved testing agencies. Valves shall be installed outdoors and so located as to be readily accessible in case of fire. Signs indicating the use of valves shall be conspicuously posted.

M103.8 Local alarm. Any one system with 20 or more sprinklers under control of one valve shall be complemented with a local fire alarm, either electrically or mechanically operated."

(2020, ord 20-61, sec 3.)

Section 5A-3-24. Appendix U; Hawai'i Hurricane Sheltering Provisions for New Construction.

Appendix U is added to read as follows:

**“APPENDIX U
HAWAI'I HURRICANE SHELTERING PROVISIONS
FOR NEW CONSTRUCTION**

Section U101. Community Storm Shelters.

Chapter 4 is amended by adding Section 421 to read as follows:

**“SECTION 421
COMMUNITY STORM SHELTERS**

421.1 General. In addition to other applicable requirements in this code, community storm shelters and the following specific Occupancy Category IV buildings shall be constructed in accordance with ICC/NSSA-500:

- (1) Designated earthquake, hurricane or other emergency shelters.
- (2) Designated emergency preparedness, communication, and operation centers and other facilities required for emergency response.

421.1.1 Scope. This section applies to the construction of storm shelters constructed as separate detached buildings or constructed as safe rooms within buildings for the purpose of providing safe refuge from storms that produce high winds, such as hurricanes. Such structures shall be designated to be hurricane shelters.

421.2 Definitions. The following words and terms shall, for the purposes of this chapter and as used elsewhere in this code, have the meanings shown herein.

“COMMUNITY STORM SHELTER. A building, structure, or portions(s) thereof, constructed in accordance with ICC 500-08 ICC/NSSA Standard on the Design and Construction of Storm Shelters and designated for use during a severe wind storm event such as a hurricane.”

Section U102. Hawai'i Residential Safe Room.

Chapter 4 is amended by adding Section 422 to read as follows:

**“SECTION 422
HAWAII RESIDENTIAL SAFE ROOM**

422.1 Performance-based design criteria. The Residential Safe Room shall meet the minimum performance specifications of Sections 422.1.1 through 422.9, and the owner of the Residential Safe Room shall comply with Section 422.10.

422.1.1 Intent and scope. The intent of the Residential Safe Room is to temporarily provide an enhanced protection area that is either: (1) fully enclosed within a dwelling or within an accessory structure to a residence; or (2) a separate structure outside of the dwelling that meets standards pursuant to 422.1.2.1 or 422.1.2.2. All Residential Safe Rooms shall be designed and constructed to withstand the wind pressures, windborne debris impacts, and other requirements of this section.

422.1.2 Alternative standards.

- (1) **Manufactured Safe Room Designs Subject to Approval.** A manufactured safe room or safe room kit may be substituted if documentation is submitted and approved by the building official. The safe room shall be engineered, tested, and manufactured to meet or exceed the criteria of this section.
- (2) **FEMA 320 Shelter Designs Permitted.** It shall be permissible to build FEMA Shelters of up to 64 square feet of floor area with walls up to 8 feet long that are built in accordance with construction details of FEMA 320.

422.2 Site criteria. Residential Safe Rooms shall not be constructed within areas subject to stream flooding, coastal flooding or dam failure inundation within any of the following areas:

- (1) FEMA Special Flood Hazard Areas (SFHA) subject to rainfall runoff flooding or stream or flash flooding;
- (2) Coastal zones “V” or “A” identified in the Flood Insurance Rate Map (FIRM) issued by FEMA for floodplain management purposes, in which the flood hazard are tides, storm surge, waves, tsunamis, or a combination of these hazards; and
- (3) Areas subject to dam failure inundation as determined by the Department of Land and Natural Resources.

422.3 Maximum occupancy. The safe room is permitted to be used for a maximum occupancy based on at least 15 square feet per person with a maximum of 8 persons in a room of up to 128 square feet of floor area.

422.4 Provisions for exiting. The room shall be equipped with an inward-swinging door and an impact-protected operable window suitable for a means of alternative exiting in an emergency.

422.5 Design for dead, live, wind, rain, and impact loads.

422.5.1 Structural integrity criteria.

- (1) The safe room shall be built with a complete structural system and a complete load path for vertical and lateral loads caused by gravity and wind.
- (2) The building that the safe room is built within shall be assumed to be destroyed by the storm and shall not be taken as offering any protective shielding to the safe room enclosure.
- (3) The ceiling structure and wall shall be capable of supporting a superimposed debris load of the full weight of any building floors and roof above, but not less than 125 psf.
- (4) The safe room enclosure shall be capable of simultaneously resisting lateral and uplift wind pressures corresponding to a 160 mph 3-second peak gust, determined in accordance with ASCE Standard 7, Minimum Design Loads for Buildings and Other Structures, calculated using load and importance Factors of 1.0. The site exposure factor shall be based on exposure C. The gust factor and the directionality factor shall be taken as 0.85. Topographic wind amplification caused by mountainous terrain shall be considered in accordance with the building code. Internal pressure shall be determined in accordance with ASCE – 7.
- (5) The safe room shall be anchored to a foundation system capable of resisting the above loading conditions.

422.5.2 Windborne debris impact protection of building enclosure elements. The entire enclosure of the safe room, including all walls, ceilings, and openings, fixed or operable windows, and all entry doors into the safe room, shall meet or exceed Level D requirements of ASTM E 1996 (Table 422.5-1). Any wall or ceiling penetration greater than 4 square inches shall be considered an opening.

Exception: Electrical outlet boxes and interior lighting switches not penetrating more than 2.5-inches into the interior wall surface and a plumbing piping or conduit not greater than 1.5-inch in diameter shall be exempted from this requirement.

422.5.3 Cyclic pressure loading of glazing and protective systems. Impact protective systems shall meet the ASTM E 1996 cyclic pressure requirement for the loading given in Table 422.5-1.

**TABLE 422.5-1
WINDBORNE DEBRIS PROTECTION AND CYCLIC PRESSURE
CRITERIA FOR RESIDENTIAL SAFE ROOMS**

| ASTM E 1996 Missile Level Rating | Debris Missile Size | Debris Impact Speed | Enclosure Wall Ceiling, and Floor Cyclic Air Pressure Testing - maximum inward and maximum outward pressures |
|----------------------------------|--|--------------------------------|--|
| D | 2 x 4 weighing 9.0 lb. +/- 0.25 lb., and with min. length 8 ft. +/- 4-inch | 50 ft./sec. or at least 34 mph | 35 psf inward 45 psf outward |

422.6 Ventilation. The room shall be naturally ventilated to allow the enclosure to have approximately one air change every 2 hours. This requirement may be satisfied by 12 square inches of venting per occupant. There shall be at least two operable vents. The vents shall be protected by a cowling or other device that shall be impact tested to comply with ASTM E 1996 Level D. Alternatively, the room shall be evaluated to determine if the openings are of sufficient area to constitute an open or partially enclosed condition as defined in ASCE 7.

422.7 Communications. The safe room shall be equipped with a phone line and telephone that does not rely on a separate electrical power outlet. Alternatively, a wireless telephone shall be permitted to rely on an Uninterruptible Power Supply (UPS) battery device.

422.8 Construction documents. Construction documents for the Residential Safe Room shall be directly prepared by a Hawai'i licensed professional structural engineer.

422.9 Special inspection. The construction or installation of the safe room shall be verified for conformance to the drawings in accordance with Chapter 17.

422.10 Notification. The owner of the safe room shall notify the State Department of Defense and county civil defense agency of the property's Tax Map Key or Global Positioning System coordinates."

Section U102. State and County-owned public high occupancy buildings - design criteria for enhanced hurricane protection areas.

Chapter 4 is amended by adding Section 423 to read as follows:

"SECTION 423

STATE AND COUNTY-OWNED HIGH OCCUPANCY BUILDINGS - DESIGN CRITERIA FOR ENHANCED HURRICANE PROTECTION AREAS

423.1 Intent. The purpose of this section is to establish minimum life safety design criteria for enhanced hurricane protection areas in high occupancy state- and county-owned buildings occupied during hurricanes of up to Saffir Simpson Category 3.

423.2 Scope. This section shall apply to state- and county-owned buildings which are of Occupancy Category III and IV defined by Table 1604.5 and of the following specific occupancies:

- (1) Enclosed and partially enclosed structures whose primary occupancy is public assembly with an occupant load greater than 300.
- (2) Health care facilities with an occupant load of 50 or more resident patients, but not having surgery or emergency treatment facilities.
- (3) Any other state- and county-owned enclosed or partially enclosed building with an occupant load greater than 5,000.
- (4) Hospitals and other health care facilities having surgery or emergency treatment facilities.

Exception: Facilities located within flood zone V and flood zone A that are designated by the owner to be evacuated during hurricane warnings declared by the National Weather Service, shall not be subject to these requirements.

423.3 Site criteria.

423.3.1 Flood and tsunami zones. Comply with ASCE 24-05, Flood Resistant Design and Construction, based on provisions for Occupancy Category III.

- (1) Floor slab on grade shall be 1.5 foot above the Base Flood Elevation of the county's flood hazard map, or at higher elevation as determined by a modeling methodology that predicts the maximum envelope and depth of inundation including the combined effects of storm surge and wave actions with respect to a Category 3 hurricane.
- (2) Locate outside of V and Coastal A flood zones unless justified by site-specific analysis or designed for vertical evacuation in accordance with a method approved by the building official. When a building within a V or Coastal A zone is approved, the bottom of the lowest structural framing member of any elevated first floor space shall be 2 feet above the Base Flood Elevation of the county's flood hazard map, or at higher elevation as determined by a modeling methodology that predicts the maximum envelope and depth of inundation including the combined effects of storm surge and wave actions with respect to a Category 3 hurricane.
- (3) Locate outside of Tsunami evacuation zones unless justified by site-specific analysis or designed for vertical evacuation in accordance with a method approved by the building official.

423.3.2 Emergency vehicle access. Provide at least one route for emergency vehicle access. The portion of the emergency route within the site shall be above the 100-year flood elevation.

423.3.3 Landscaping and utility laydown impact hazards. Landscaping around the building shall be designed to provide standoff separation sufficient to maintain emergency vehicle access in the event of mature tree blowdown. Trees shall not interfere with the functioning of overhead or underground utility lines, nor cause laydown or falling impact hazard to the building envelope or utility lines.

423.3.4 Adjacent buildings. The building shall not be located within 1,000 feet of any hazardous material facilities defined by Table 1604.5. Unanchored light-framed portable structures shall be not permitted within 300 feet of the building.

423.4 Enhanced hurricane protection area program requirements.

423.4.1 Applicable net area. At least 50 percent of the net square feet of a facility shall be constructed to qualify as an enhanced hurricane protection area. The net floor area shall be determined by subtracting from the gross square feet the floor area of excluded spaces, exterior walls, columns, fixed or movable objects, equipment or other features that under probable conditions cannot be removed or stored during use as a storm shelter.

423.4.2 Excluded spaces. Spaces such as mechanical and electrical rooms, storage rooms, attic and crawl spaces, shall not be considered as net floor area permitted to be occupied during a hurricane.

423.4.3 Occupancy capacity. The occupancy capacity shall be determined by dividing the net area of the enhanced hurricane protection area by 15 square feet net floor area per person.

423.4.4 Toilets and hand washing facilities. Provide a minimum of 1 toilet per 50 enhanced hurricane protection area occupants and a minimum of 1 sink per 100 enhanced hurricane protection area occupants, as determined per Section 423.4.3, located within the perimeter of the enhanced hurricane protection area. These required toilet and hand-washing facilities are not in addition to those required for normal occupancy and shall be included in the overall facility fixture count.

423.4.5 Accessibility. Where the refuge occupancy accommodates more than 50 persons, provide an ADA-accessible route to a shelter area at each facility with a minimum of 1 wheelchair space for every 200 enhanced hurricane protection area occupants determined per Section 423.4.3.

423.5 Design wind, rain, and impact loads.

423.5.1 Structural design criteria. The building Main Wind Force Resisting System and structural components shall be designed per ASCE 7 for a 115 mph minimum peak 3-second gust design speed with a load factor of 1.6, and an Importance Factor for Occupancy Category III. Topographic and directionality factors shall be the site-specific values determined per Appendix W. Design for interior pressure based on the largest opening in any exterior facade or roof surface.

423.5.2 Windborne debris missile impact for building enclosure elements. Exterior glazing and glazed openings, louvers, roof openings and doors shall be provided with windborne debris impact resistance or protection systems conforming to ASTM E1996-05 Level D, i.e., 9 lb. 2 X 4 @ 50 fps (34 mph).

423.5.3 Cyclic pressure loading of impact resistive glazing or windborne impact protective systems. Resistance to the calculated maximum inward and outward pressure shall be designed to conform to ASTM E1996-05.

423.5.4 Windows. All unprotected window assemblies and their anchoring systems shall be designed and installed to meet the wind load and missile impact criteria of this section.

423.5.5 Window protective systems. Windows may be provided with permanent or deployable protective systems, provided the protective system is designed and installed to meet the wind load and missile impact criteria and completely covers the window assembly and anchoring system.

423.5.6 Doors. All exterior and interior doors subject to possible wind exposure and/or missile impact shall have doors, frames, anchoring devices, and vision panels designed and installed to resist the wind load and missile impact criteria or such doors, frames, anchoring devices, and vision panels shall be provided with impact protective systems designed and installed to resist the wind load and missile impact criteria of this section.

423.5.7 Exterior envelope. The building enclosure, including walls, roofs, glazed openings, louvers and doors, shall not be perforated or penetrated by windborne debris, as determined by compliance with ASTM E1996-05 Level C.

423.5.8 Parapets. Parapets shall satisfy the wind load and missile impact criteria of the exterior envelope.

423.5.9 Roofs.

423.5.9.1 Roof openings. Roof openings (e.g., HVAC fans, ducts, skylights) shall be provided with protection for the wind load and missile impact criteria of Sections 423.5.2 and 423.5.3.

423.5.9.2 High wind roof coverings. Roof coverings shall be specified and designed according to the latest ASTM Standards for high wind uplift forces.

423.5.9.3 Roof drainage. Roofs shall have adequate slope, drains and overflow drains or scuppers sized to accommodate 100-year hourly rainfall rates in accordance with Section 1611.1, but not less than 2-inches per hour for 6 continuous hours.

423.6 Ventilation.

423.6.1 Mechanical ventilation. Mechanical ventilation as required per the International Mechanical Code. Air intakes and exhausts shall be designed and installed to meet the wind load and missile impact criteria of Sections 423.5.2 and 423.5.3.

423.6.2 HVAC equipment anchorage. HVAC equipment mounted on roofs and anchoring systems shall be designed and installed to meet the wind load criteria. Roof openings for roof-mounted HVAC equipment shall have a 12-inch-high curb designed to prevent the entry of rain water.

423.7 Standby electrical system capability. Provide a standby emergency electrical power system per Chapter 27 and NFPA 70 Article 700 Emergency Systems and Article 701 Legally Required Standby Systems, which shall have the capability of being connected to an emergency generator or other temporary power source. The emergency system capabilities shall include:

- (1) An emergency lighting system,
- (2) Illuminated exit signs,
- (3) Fire protection system(s), alarm and sprinkler, and
- (4) Minimum mechanical ventilation for health/safety purposes.

423.7.1 Emergency generator. When emergency generators are pre-installed, the facility housing the generator, permanent or portable, shall be an enclosed area designed to protect the generators from wind and missile impact. Generators hardened by the manufacturer to withstand the area's design wind and missile impact criteria shall be exempt from the enclosed area criteria requirement.

423.8 Quality assurance.

423.8.1 Information on construction documents. Construction Documents shall include design criteria, the occupancy capacity of the enhanced hurricane protective area, and Project Specifications shall include opening protection devices. Floor plans shall indicate all enhanced hurricane protection area portions of the facility and exiting routes there from. The latitude and longitude coordinates of the building shall be recorded on the construction documents.

423.8.2 Special inspection. In addition to the requirements of Chapter 17, special inspections shall include at least the following systems and components:

- (1) Roof cladding and roof framing connections.
- (2) Wall connections to roof and floor diaphragms and framing.
- (3) Roof and floor diaphragm systems, including collectors, drag struts and boundary elements.
- (4) Vertical windforce-resisting systems, including braced frames, moment frames and shear walls.
- (5) Windforce-resisting system connections to the foundation.
- (6) Fabrication and installation of systems or components required to meet the impact-resistance requirements of Section 1609.1.2.

Exception: Fabrication of manufactured systems or components that have a label indicating compliance with the wind-load and impact-resistance requirements of this code.

423.8.3 Quality assurance plan. A construction quality assurance program shall be included in the Construction Documents, including:

- (1) The materials, systems, components and work required to have special inspection or testing by the building official or by the registered design professional responsible for each portion of the work.
- (2) The type and extent of each special inspection.
- (3) The type and extent of each test.
- (4) Additional requirements for special inspection or testing for seismic or wind resistance.
- (5) For each type of special inspection, identification as to whether it will be continuous special inspection or periodic special inspection.

423.8.4 Peer review. Construction Documents shall be independently reviewed by a Hawai'i-licensed Structural Engineer. A written opinion report of compliance shall be submitted to State Civil Defense, the Building Official, and the owner.

423.9 Maintenance. The building shall be periodically inspected every three years and maintained by the owner to ensure structural integrity and compliance with this section. A report of inspection shall be furnished to State Civil Defense.

423.10 Compliance re-certification when altered, deteriorated, or damaged. Alterations shall be reviewed by a Hawai'i-licensed structural engineer to determine whether any alterations would cause a violation of this section. Deterioration or damage to any component of the building shall require an evaluation by a Hawai'i-licensed structural engineer to determine repairs necessary to maintain compliance with this section.”

(2020, ord 20-61, sec 3.)

Section 5A-3-25. Appendix W; Hawai'i Wind Design Provisions for New Construction.

Appendix W is added to read as follows:

**“APPENDIX W
HAWAI'I WIND DESIGN PROVISIONS FOR NEW CONSTRUCTIONS**

W101 Revisions to Chapter 16. When Appendix W is adopted, wind design shall be in accordance with Chapter 16 as amended by Sections W101.1 through W101.10.

W101.1 Revisions to section 1603.1. Section 1603.1 is amended to read as follows:

“1603.1 General. Construction documents shall show the size, section, and relative locations of structural members with floor levels, column centers and offsets dimensioned. The design loads and other information pertinent to the structural design required by Sections 1603.1.1 through 1603.1.8 shall be indicated on the construction documents.

Exception: Construction documents for buildings constructed in accordance with the conventional light-frame construction provisions of Section 2308 shall indicate the following structural design information:

- (1) Floor and roof live loads.
- (2) Ground snow load, P_g .
- (3) Basic wind speed (3-second gust) and Effective wind speed V_{eff} (3-second gust), miles per hour (mph)(km/hr) and wind exposure.
- (4) Seismic design category and site class.
- (5) Flood design data, if located in flood hazard areas established in Section 1612.3.”

W101.2 Revisions to section 1603.1.4. Section 1603.1.4 is amended to read as follows:

“1603.1.4 Wind design data. The following information related to wind loads shall be shown, regardless of whether wind loads govern the design of the lateral-force-resisting system of the building:

- (1) Basic wind speed (3-second gust), miles per hour (km/hr), V , and effective windspeed V_{eff} .
- (2) Wind importance factor I , and building category.
- (3) Wind exposure, if more than one wind exposure is utilized, the wind exposure for each applicable wind direction shall be indicated.
- (4) The applicable internal pressure coefficient.
- (5) Components and cladding. The design wind pressures in terms of psf (kN/m^2) used for the design of exterior components, and cladding not specifically designed by the registered design professional.”

W101.3 Revisions to section 1609.1.1. Section 1609.1.1 is amended to read as follows:

“1609.1.1 Determination of wind loads. Wind loads on every building or structure shall be determined in accordance with Chapter 6 of ASCE 7. Minimum values for Directionality Factor, K_d , Velocity Pressure Exposure Coefficient, K_z , and Topographic Factor, K_{zt} , shall be determined in accordance with Section 1609. The type of opening protection required, the basic wind speed and the exposure category for a site is permitted to be determined in accordance with Section 1609 or ASCE 7. Wind shall be assumed to come from any horizontal direction and wind pressures shall be assumed to act normal to the surface considered.

Exceptions:

- (1) Subject to the limitations of Section 1609.1.1.1, the provisions of SBCCI SSTD 10 shall be permitted for applicable Group R-2 and R-3 buildings.
- (2) Subject to the limitations of Section 1609.1.1.1, residential structures using the provisions of the AF & PA WFCM.
- (3) Designs using NAAMM FP 1001.
- (4) Designs using TIA/EIA-222 for antenna-supporting structures and antennas.”

W101.4 Revisions to section 1609.1.2. Section 1609.1.2 is amended to read as follows:

“1609.1.2 Protection of openings. In wind-borne debris regions, glazing in building shall be impact-resistant or protected with an impact-resistant covering meeting the requirements of an approved impact-resisting standard or ASTM E 1996 and of ASTM E 1886 referenced therein as follows:

- (1) Glazed openings located within 30 feet (9144 mm) of grade shall meet the requirements of the Large Missile Test of ASTM E 1996.
- (2) Glazed openings located more than 30 feet (9144 mm) above grade shall meet the provisions of the Small Missile Test of ASTM E 1996.

Exceptions:

- (1) Wood structural panels with a minimum thickness of 7/16 inch (11.1 mm) and a maximum panel span of 8 feet (2438 mm) shall be permitted for opening protection in one- and two-story buildings. Panels shall be precut so that they shall be attached to the framing surrounding the opening containing the product with the glazed opening. Panels shall be secured with the attachment hardware provided. Attachments shall be designed to resist the components and cladding loads determined in accordance with the provisions of ASCE 7. Attachment in accordance with Table 1609.1.2 is permitted for buildings with a mean roof height of 33 feet (10,058 mm) or less where wind speeds do not exceed 130 mph (57.2 m/s).
- (2) Glazing in Occupancy Category I buildings as defined in Section 1604.5, including greenhouses that are occupied for growing plants on a production or research basis, without public access shall be permitted to be unprotected.
- (3) Glazing in Occupancy Category II, III or IV buildings located over 60 feet (18,288 mm) above the ground and over 30 feet (9,144 mm) above aggregate surface roofs located within 1,500 feet (458 m) of the building shall be permitted to be unprotected.
- (4) Glazing in Occupancy Category II and III buildings that can receive positive external pressure in the lower 60 feet (18,288 mm) shall be assumed to be openings unless such glazing is impact-resistant or protected with an impact-resistant system.

Exception: Glazing in Occupancy Category III buildings defined by Table 1604.5 of the following occupancies shall be provided with windborne debris protection:

- (a) Covered structures whose primary occupancy is public assembly with an occupant load greater than 300.
- (b) Health care facilities with an occupant load of 50 or more resident patients, but not having surgery or emergency treatment facilities.
- (c) Any other public building with an occupant load greater than 5,000.

1609.1.2.1 Building with openings. Where glazing is assumed to be an opening in accordance with Section 1609.1.2, the building shall be evaluated to determine if the openings are of sufficient area to constitute an open or partially enclosed building as defined in ASCE 7. Open and partially enclosed buildings shall be designed in accordance with the applicable provisions of ASCE 7. Partially enclosed Occupancy R-3 buildings shall also include a residential safe room in accordance with Section 422, Hawaii Residential Safe Room.

1609.1.2.2 Louvers. Louvers protecting intake and exhaust ventilation ducts not assumed to be open that are located within 30 ft (9,144 mm) of grade shall meet requirements of an approved impact-resisting standard or the Large Missile Test of ASTM E 1996.

**TABLE 1609.1.2
WIND-BORNE DEBRIS PROTECTION FASTENING SCHEDULE
FOR WOOD STRUCTURAL PANELS ^{a,b,c}**

| FASTENER TYPE | FASTENER SPACING | | |
|----------------------|--------------------------------|--|--|
| | Panel span ≤ 4 feet | 4 feet < Panel span ≤ 6 feet | 6 feet < Panel span ≤ 8 feet |
| No. 6 screws | 16" | 12" | 9" |
| No. 8 screws | 16" | 16" | 12" |

For SI: 1 inch = 25.4 mm, 1 foot = 304.8 mm, 1 pound = 0.454 kg,
1 mile per hour = 1.609 km/h.

- a. This table is based on a maximum wind speed (3-second gust) of 130 mph and mean roof height of 33 feet or less.
- b. Fasteners shall be installed at opposing ends of the wood structural panel. Fasteners shall be located a minimum of 1 inch from the edge of the panel.

- c. Fasteners shall be long enough to penetrate through the exterior wall covering a minimum of 1.75 inches into wood wall framing; a minimum of 1.25 inches into concrete block or concrete; or into steel framing by at least three threads. Fasteners shall be located a minimum of 2.5 inches from the edge of concrete block or concrete.
- d. Where screws are attached to masonry or masonry/stucco, they shall be attached utilizing vibration-resistant anchors having a minimum withdrawal capacity of 490 pounds.”

W101.4.1 Revisions to section 1609.2. Section 1609.2 is amended to read as follows:

“1609.2 Definitions. The following words and terms shall, for the purposes of Section 1609, have the meanings shown herein.

HURRICANE-PRONE REGIONS. Areas vulnerable to hurricanes defined as:

- (1) The U.S. Atlantic Ocean and Gulf of Mexico coasts where the basic wind speed is greater than 90 mph (40 m/s) and
- (2) Hawai‘i, Puerto Rico, Guam, Virgin Islands and American Samoa.

WIND-BORNE DEBRIS REGION. Portions of hurricane-prone regions that are within 1 mile (1.61 km) of the coastal mean high water line where the basic wind speed is 110 mph (48 m/s) or greater; or portions of hurricane-prone regions where the basic wind speed is 120 mph (53 m/s) or greater.”

W101.5 Revisions to section 1609.3. Section 1609.3 is amended to read as follows:

“1609.3 Basic wind speed and topographic and directionality factors. The basic wind speed, in mph, for the determination of the wind loads shall be determined by Figure 1609.

Special wind regions near mountainous terrain and valleys are accounted within the Topographic Factor defined in Section 1609.3.3. Wind speeds derived from simulation techniques shall only be used in lieu of the basic wind speeds given in Figure 1609 when, (1) approved simulation or extreme-value statistical-analysis procedures are used (the use of regional wind speed data obtained from anemometers is not permitted to define the hurricane wind speed risk in Hawai‘i) and (2) the design wind speeds resulting from the study shall not be less than the resulting 700-year return period wind speed divided by $\sqrt{1.6}$.”

W101.6 Addition of section 1609.3.2. Section 1609.3.2 is added to read as follows:

“1609.3.2 Effective basic wind speed conversion. For Section 2308.10.1, the provisions of ASCE Section 6.4, and the exceptions permitted under Section 16099.1.1, the basic wind speed value used for determination of the wind loads, shall be the Effective Basic Wind Speed, V_{eff} , determined by Figure 1609.1.1.1, which adjusts the basic wind speed for special topographic wind regions.”

W101.7 Addition of effective wind speed contour maps.

Figure 1609.1.1.1(a) is added as follows:

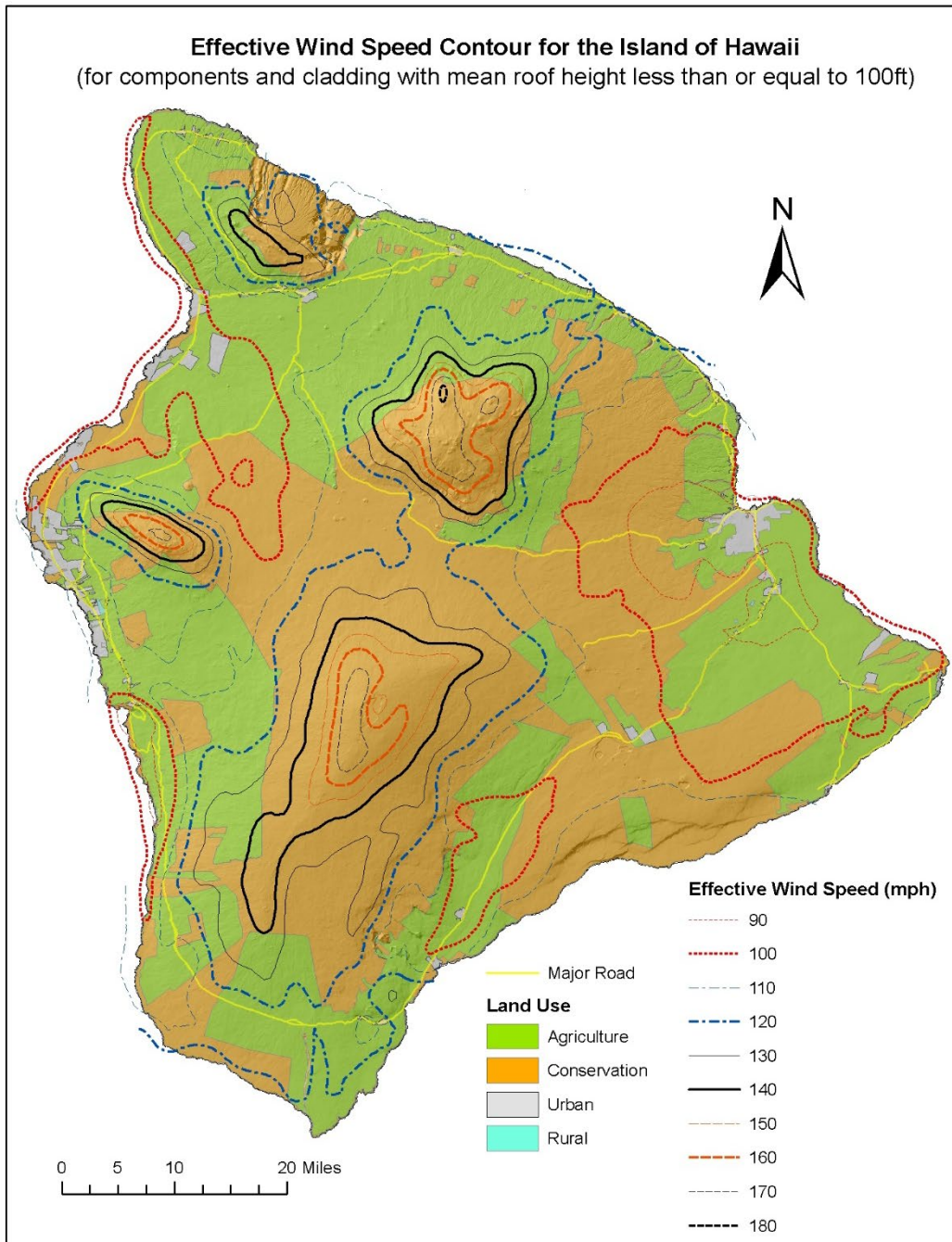

Figure 1609.1.1.1(a)
County of Hawai'i Effective Basic Wind Speed, V_{eff} , for Components and Cladding for Buildings less than 100 ft. tall

W101.8 Addition of section 1609.3.3. Section 1609.3.3 is added to read as follows:

“1609.3.3 Topographic effects. Wind speed-up effects caused by topography shall be included in the calculation of wind loads by using the factor K_{zt} , where K_{zt} is given in Figure 1609.3.3(a).

Exception: Site-specific probabilistic analysis of directional K_{zt} based on wind-tunnel testing of topographic speed-up shall be permitted to be submitted for approval by the Building Official.”

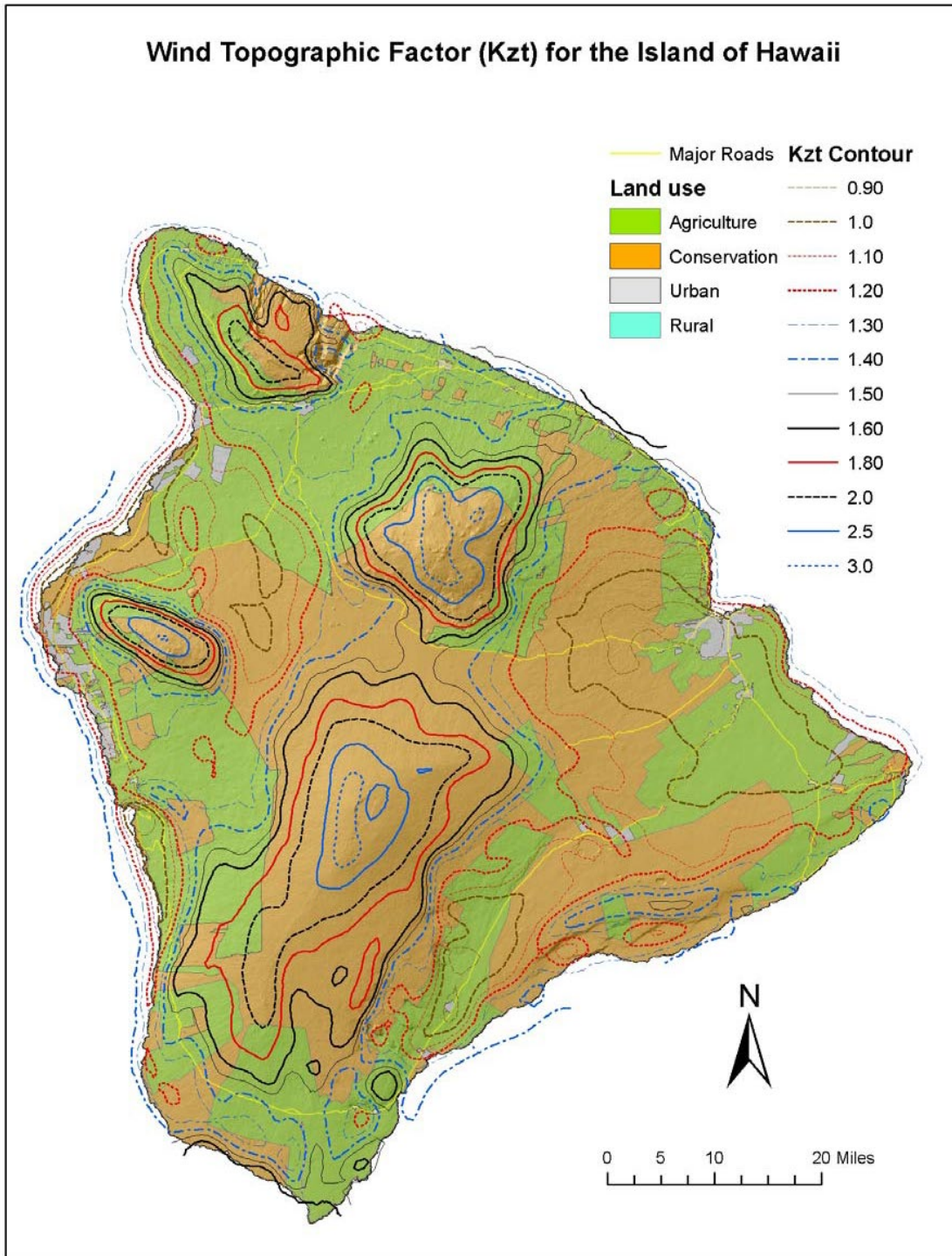

Figure 1609.3.3(a)
County of Hawai'i Peak Gust Topographic Factor K_{zt}

W101.9 Directionality factor. Section 1609.3.4 is added to read as follows:

“1609.3.4 Directionality factor. The wind directionality factor, K_d , shall be determined from Tables 1609.3.4(a) and 1609.3.4(b).

**TABLE 1609.3.4(a)(1)
K_d VALUES FOR MAIN WIND FORCE RESISTING SYSTEMS
SITED IN HAWAII COUNTY ^{a,b}**

| Topographic Location on the Island of Hawaii | Main Wind Force Resisting Systems | | Main Wind Force Resisting Systems with totally independent systems in each orthogonal direction | | Biaxially Symmetric and Axisymmetric Structures of any Height and Arched Roof Structures |
|---|--|---------------------------------------|---|---------------------------------------|--|
| | Mean Roof Height less than or equal to 100 ft. | Mean Roof Height greater than 100 ft. | Mean Roof Height less than or equal to 100 ft. | Mean Roof Height greater than 100 ft. | |
| Sites in North Kohala, South Kohala, South Kona, South Hilo, and Puna Districts at an elevation not greater than 3000 ft. | 0.65 | 0.70 | 0.70 | 0.75 | 0.85 |
| All other sites | 0.70 | 0.80 | 0.75 | 0.80 | 0.95 |

- a. The values of K_d for other non-building structures indicated in ASCE-7 Table 6-4 shall be permitted.
- b. Site-specific probabilistic analysis of K_d based on wind-tunnel testing of topography and peak gust velocity profile shall be permitted to be submitted for approval by the Building Official, but K_d shall have a value not less than 0.65.

TABLE 1609.3.4(b)(1)
K_d VALUES FOR COMPONENTS AND CLADDING
OF BUILDINGS SITED IN HAWAII COUNTY ^{a,b}

| Topographic Location on the Island of Hawai'i | Components and Cladding | | |
|---|--|---------------------------------------|--|
| | Mean Roof Height less than or equal to 100 ft. | Mean Roof Height greater than 100 ft. | Occupancy Category IV Buildings and Structures |
| Sites in North Kohala, South Kohala, South Kona, South Hilo, and Puna Districts at an elevation not greater than 3000 ft. | 0.65 | 0.70 | 0.75 |
| All other sites | 0.75 | 0.80 | 0.85 |

- a. The values of K_d for other non-building structures indicated in ASCE-7 Table 6-4 shall be permitted.
- b. Site-specific probabilistic analysis of K_d based on wind-tunnel testing of topography and peak gust velocity profile shall be permitted to be submitted for approval by the Building Official, but in any case subject to a minimum value of 0.65.”

W101.10 Addition of exposure category maps. Section 1609.4.4 is added to read as follows:

“**1609.4.4 Exposure category maps.** Exposure categories are permitted to be determined using Figure 1609.4.4(a).

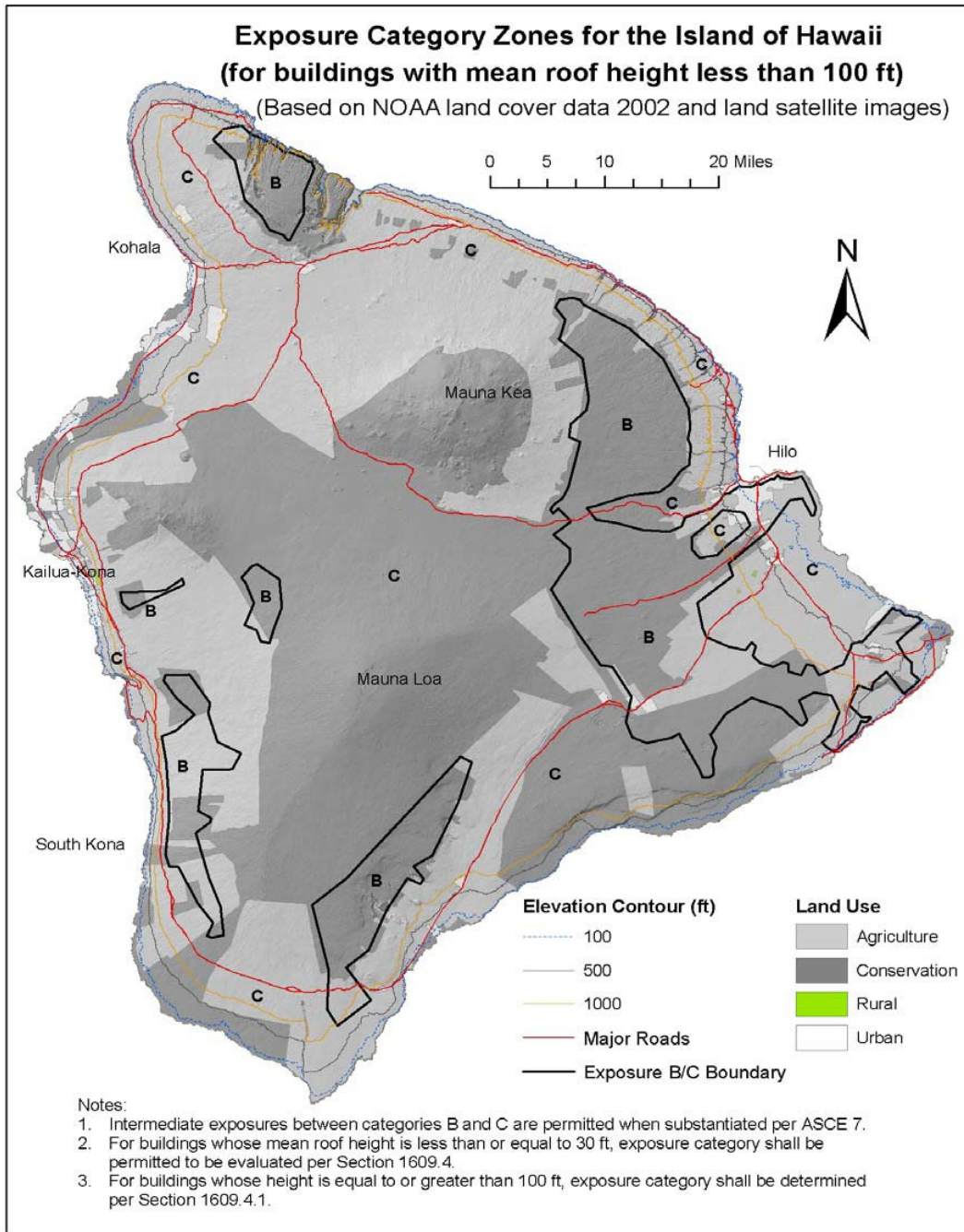

Figure 1609.4.4(a)
 Exposure Category Zones for Hawai'i County

W102 Revisions to chapter 23. When Appendix W is adopted, wood construction shall be in accordance with Chapter 23 as amended by Sections W102.1 and W102.2.

W102.1 Revisions to section 2308.2.1. Section 2308.2.1 is amended to read as follows:

“**2308.2.1 Basic wind speed greater than 100 mph.** Where the Effective Basic Wind Speed exceeds 100 mph, the provisions of the AF&PA WFCM, or the SBCCI SSTD 10 are permitted to be used.”

W102.2 Revisions to table 2308.10.1. Table 2308.10.1 is amended to read:

**TABLE 2308.10.1
REQUIRED RATING OF APPROVED UPLIFT CONNECTORS
(pounds)^{a,b,c,d,e,f,g,h,i}**

| Effective Basic Wind Speed | Roof Span (feet) | | | | | | | Overhangs (pounds/ft) ^d |
|--|------------------|------|------|------|------|------|-------|------------------------------------|
| | 12 | 20 | 24 | 28 | 32 | 36 | 40 | |
| ^v _{eff} , 3-sec gust | | | | | | | | |
| 85 | -72 | -120 | -144 | -168 | -192 | -216 | -240 | -38.55 |
| 90 | -91 | -152 | -182 | -213 | -243 | -274 | -304 | -43.22 |
| 100 | -131 | -218 | -262 | -305 | -349 | -392 | -436 | -53.36 |
| 110 | -175 | -292 | -350 | -409 | -467 | -526 | -584 | -64.56 |
| 120 | -240 | -400 | -480 | -560 | -640 | -720 | -800 | -76.83 |
| 130 | -304 | -506 | -607 | -708 | -810 | -911 | -1012 | -90.17 |

For SI: 1 inch = 25.4 mm, 1 foot = 304.8 mm, 1 mile per hour = 1.61 km/hr, 1 pound = 0.454 Kg, 1 pound/foot = 14.5939 N/m.

a. The uplift connection requirements are based on a 30-foot mean roof height located in Exposure B. For Exposure C and for other mean roof heights, multiply the above loads by the adjustment coefficients below.

| EXPOSURE | Mean Roof Height (feet) | | | | | | | | | |
|----------|-------------------------|------|------|------|------|------|------|------|------|------|
| | 15 | 20 | 25 | 30 | 35 | 40 | 45 | 50 | 55 | 60 |
| B | 1.00 | 1.00 | 1.00 | 1.00 | 1.05 | 1.09 | 1.12 | 1.16 | 1.19 | 1.22 |
| C | 1.21 | 1.29 | 1.35 | 1.40 | 1.45 | 1.49 | 1.53 | 1.56 | 1.59 | 1.62 |

For SI: 1 inch – 25.4 mm, 1 foot = 304.8 mm, 1 mile per hour = 1.61 km/hr, 1 pound = 0.454 Kg, 1 pound/foot = 14.5939 N/m.

b. The uplift connection requirements are based on the framing being spaced 24 inches on center. Multiply by 0.67 for framing spaced 16 inches on center and multiply by 0.5 for framing spaced 12 inches on center.

c. The uplift connection requirements include an allowance for 10 pounds of dead load.

- d. The uplift connection requirements do not account for the effects of overhangs. The magnitude of the above loads shall be increased by adding the overhang loads found in the table. The overhang loads are also based on framing spaced 24 inches on center. The overhang loads given shall be multiplied by the overhang projection and added to the roof uplift value in the table.
 - e. The uplift connection requirements are based upon wind loading on end zones as defined in Figure 6-2 of ASCE 7. Connection loads for connections located a distance of 20 percent of the least horizontal dimensions of the building from the corner of the building are permitted to be reduced by multiplying the table connection value by 0.7 and multiplying the overhang load by 0.8.
 - f. For wall-to-wall and wall-to-foundation connections, the capacity of the uplift connector is permitted to be reduced by 100 pounds for each full wall above. (For example, if a 500-pound rated connector is used on the roof framing, a 400-pound rated connector is permitted at the next floor level down.)
 - g. Interpolation is permitted for intermediate values of basic wind speeds and roof spans.
 - h. The rated capacity of approved tie-down devices is permitted to include up to a 60-percent increase for wind effects where allowed by material specifications.
 - i. V_{eff} is given by Figure 1609.1.1.1.”
- (2020, ord 20-61, sec 3.)

Section 5A-3-26. Appendix X; Indigenous Hawaiian Architecture Structures.

Appendix X is added to read as follows:

**“APPENDIX X
INDIGENOUS HAWAIIAN ARCHITECTURE STRUCTURES**

**SECTION X101
GENERAL**

X101.1 Scope. The provisions of this appendix shall apply exclusively to Indigenous Hawaiian Architecture Structures. The purpose of these provisions is to acknowledge and establish procedures for designing and constructing indigenous Hawaiian architecture structures.

X101.2 Publications incorporated by reference. The following publications are incorporated by reference and made a part of these provisions. Where there is a conflict between Appendix X and the referenced documents, Appendix X shall prevail.

- (1) “Hawaiian Thatched House” (1971), by Russell A. Apple, published by the United States Department of the Interior,
- (2) “Hale Construction Standards” (2000), by Francis Sinenci and Bill Sides,
- (3) “The Hawaiian Grass House in Bishop Museum” (1988), by Catherine C. Summers, and

- (4) “Arts and Crafts of Hawaii, Section II, Houses” (1957) by Te Rangi Hiroa (Peter H. Buck)

X101.3 Definitions. For purposes of this appendix, the following words and terms shall have the meanings shown herein. Refer to Chapter 2 for general definitions.

“CERTIFIED HALE BUILDER. Means a person who has obtained a certificate of completion for satisfactorily completing a course in Hawaiian hale construction from the University of Hawai‘i, or any of its community colleges, or as approved by the Building Official.”

“GROUP OF STRUCTURES. A group of indigenous Hawaiian architecture structures that are in close proximity to each other and have an aggregate floor area of 1,800 square feet or less.”

“INDIGENOUS HAWAIIAN ARCHITECTURE STRUCTURE or HALE. A structure that is consistent with the design, construction methods and uses of structures built by Hawaiians in the 1800’s, which uses natural materials found in the Hawaiian islands, and complies with this appendix and references.”

“SEPARATION. The clear distance between two structures.”

“SETBACK. The clear distance between a structure and a property line.”

SECTION X201 MATERIAL REQUIREMENTS

X201.1 Hale materials. Hale shall be constructed using only materials grown and harvested in the State of Hawai‘i.

X201.2 Wood framing material. The wood members for the hale, such as posts and rafters, shall be, but not limited to hardwoods of unmilled, straight sections of trunks or branches of the following species:

- (1) Casaurina equisitifolia (ironwood).
- (2) Prosopis-allid (kiawe).
- (3) Eucalyptus robusta (eucalyptus).
- (4) Psidium cattleianum (strawberry guava).
- (5) Metrosideros polymorpha (ohia).
- (6) Rizophora mangle (mangrove).

Exception: *Ardisia elliptica* (inkberry) may be used only for roof purlins as an alternative to specified woods listed in Items 1 through 6.

X201.3 Roofing and siding. Thatched roofing and siding materials for the hale may be any grass or leaf material grown and harvested in the State of Hawai'i, to include but not be limited to pili, kualohia, pueo, kawelu, sugar-cane leaves, and ti leaves.

X201.4 Cord. Natural or synthetic cord used for lashing structural members of the hale shall be 400 pound test. Cord used for tying floating purlins and thatched materials shall be 100 pound test. All cord used on the hale shall be shades of green, tan, brown or black.

X201.5 Metal prohibited. Metal shall not be used for the construction of the hale.

**SECTION X202
SIZE AND LOCATION**

X202.1 Height and size limitation. Hale shall be one-story, detached structure(s) not to exceed 1,800 square feet. Hale shall not exceed the size indicated in Table X202.1.

**TABLE X202.1
MAXIMUM SIZE OF HALE (FEET)**

| Hale Halawai | Hale Ku'ai | Hale Noa | Hale Wa'a |
|--------------|------------|----------|-----------|
| 30 X 60 | 14 X 20 | 14 X 24 | 30 X 60 |

X202.2 Zoning requirements. Hale shall comply with minimum yard requirements in Chapter 25, Zoning Code, Hawai'i County Code.

X202.3 Minimum separation. The minimum separation between a hale and another structure shall be at least 10 feet for a one-story structure; 15 feet for a two-story structure; or a distance equal to the height of the hale, whichever is more. The minimum separation between two hale shall be at least 10 feet or a distance equal to the height of the taller hale.

X202.4 Hale Noa. Hale noa structures may only be constructed on property where a separate residence exists on the property.

**SECTION X203
ALLOWABLE AND PROHIBITED USES**

X203.1 Allowable uses. To the extent permitted by other applicable law, allowable uses for hale structures shall be in accordance with Table X203.1.

**TABLE X203.1
ALLOWABLE USE FOR EACH HALE TYPE**

| Use | Hale Halawai | Hale Ku'ai | Hale Noa | Hale Wa'a |
|----------------------------------|---------------------|-------------------|-----------------|------------------|
| Eating (ai) | Allowed | Allowed | Not permitted | Allowed |
| Assembling (halawai) | Allowed | Allowed | Not permitted | Allowed |
| Sleeping (moe) | Not permitted | Not permitted | Allowed | Not permitted |
| Retailing (e.g., fruits) (ku'ai) | Allowed | Allowed | Not permitted | Allowed |
| Storage (papa'a) | Not permitted | Allowed | Not permitted | Allowed |

X203.2 Prohibited uses and activities. The following uses and activities shall be prohibited from occurring within or near the hale:

- (1) Cooking.
- (2) Open flames.
- (3) Generators.
- (4) Extension cords.
- (5) Electrical switches, fixtures, or outlets.
- (6) Plumbing faucets, fixtures, or drains.
- (7) Power tools.
- (8) No screen, mesh, plastic or any other similar material shall be attached to the hale.
- (9) Hale shall not be used as a food establishment as defined in the administrative rules adopted by the State of Hawai'i, Department of Health.

X203.3 Maintenance. The hale shall be maintained by the owner to ensure structural integrity. Repairs for maintenance of the hale shall not require additional building permits.

**SECTION X301
FIRE PROTECTION**

X301.1 Fire protection classifications. Fire protection for Indigenous Hawaiian architecture structures shall be as required in Table X301.1.

**TABLE X301.1
FIRE PROTECTION REQUIREMENTS BASED ON SETBACK**

| CLASS | SETBACK REQUIREMENTS | FIRE PROTECTION REQUIREMENTS |
|--------------|--|--|
| A | <p>The structure (or a group of structures) is:</p> <ol style="list-style-type: none"> 1. Located at least 100 feet from any existing structure on the same or neighboring properties; and 2. Located at least 100 feet from any property line, except as follows: <ol style="list-style-type: none"> a. If the property line abuts a public way, the 100 feet minimum setback for that property line shall be reduced by the width of the public way, b. If the property line abuts the shoreline, the minimum setback for that property line shall be the shoreline setback, or c. For any Hale Ku'ai in the agricultural district that is less than 200 square feet, that is completely open on three sides, and that is used as an agricultural products stand and if the property line abuts a public way, the minimum setback for that property line shall be 15 feet. | <p>No fire protection is required for the structure.</p> |
| B | <p>The structure (or a group of structures) that conforms to applicable zoning setback requirements but does not satisfy Class A setback requirements.</p> | <p>Automatic fire sprinkler system shall be installed in accordance with design standards in Section X301.2. An electrical permit is required for fire sprinklers systems.</p> |

X301.2 Automatic fire sprinklers. The design standards for automatic fire sprinklers for Class B indigenous Hawaiian architecture structures shall be in accordance with NFPA 13.

Exception: The design standards for automatic fire sprinklers for Class B indigenous Hawaiian architecture structures shall be permitted as follows:

- (1) 18 gallons per minute for a single head at 140 square feet maximum coverage of roof area.
- (2) 13 gallons per minute for each subsequent head at 140 square feet maximum coverage of roof area per head.
- (3) The minimum supply pressure at the base of the riser shall not be less than 40 pounds per square inch.
- (4) The minimum residual pressure at the highest sprinkler shall be not less than 12 pounds per square inch.
- (5) Sprinkler head spacing shall not exceed 14 feet.
- (6) Sprinkler heads shall be open type upright, pendent, or sidewall with 1/2-inch or 17/32-inch orifice and have a wax corrosion resistant coating.
- (7) The total number of sprinklers on a branch shall not exceed 6 heads.
- (8) The total number of sprinklers shall not exceed the quantity shown in the following table:

| Piping Size | Number of Sprinklers |
|---------------------|----------------------|
| 1 inch diameter | 2 sprinklers |
| 1-1/4 inch diameter | 3 sprinklers |
| 1-1/2 inch diameter | 5 sprinklers |
| 2 inch diameter | 10 sprinklers |
| 2-1/2 inch diameter | 30 sprinklers |
| 3 inch diameter | 60 sprinklers |

- (9) The above pipe schedule shall not apply to hydraulically designed systems.
- (10) The water density shall not be less than 0.10 gpm per square foot.
- (11) The source of water may be by domestic water meters, detector check meter, underground well, storage tank, swimming pool, ponds, etc., but must meet the design requirements for adequate pressure and duration.

- (12) Water supply shall be sufficient to provide 30 minutes duration.
- (13) If domestic water meters are used as the source of water for the fire sprinklers, without a storage tank and booster pump, the maximum number of heads shall not exceed the following table:

| Size of Water Meter | Number of Sprinklers |
|------------------------|----------------------|
| 5/8 inch water meter | 1 sprinkler |
| 3/4 inch water meter | 2 sprinklers |
| 1 inch water meter | 3 sprinklers |
| 1-1/2 inch water meter | 7 sprinklers |
| 2 inch water meter | 11 sprinklers |
| 3 inch water meter | 27 sprinklers |

- (14) The piping material shall be hard drawn copper with silver solder or brazed fittings, or carbon steel with corrosion-resistant coatings. Plastic pipes shall not be allowed, except for below grade supply pipes.
- (15) Fire sprinkler system shall be actuated by smoke detectors located at the highest points of the roof and spaced as recommended by the manufacturer.
- (16) Flow control valves shall be either hydraulically or electrically operated with a manual override switch.
- (17) Where the width of a roof exceeds the width allowed for one row of sprinklers, two or more rows of sprinklers shall be placed such that the entire roof area is protected.
- (18) Prevailing wind direction shall be considered in the placement of sprinklers.
- (19) Deflectors for sprinklers shall be parallel with the roof surface or tilted slightly towards the peak of the roof.
- (20) Fire sprinklers system shall have a local alarm activated by a smoke detector.

X301.3 Certification of water supply. For any hale that requires fire protection pursuant to X301.1, the applicant shall provide a certification from a licensed engineer or a licensed C-20 contractor that the water supply for the fire sprinkler system has been tested and is capable of delivering the required fire flow for 30 minutes duration.

X302 Smoke alarm. Any hale used for sleeping shall have an approved battery operated smoke alarm installed in the hale.

**SECTION X401
DESIGN STANDARDS**

X401.1 General design standards. All types of hale shall be designed and constructed in accordance with the standards set out in this section.

- (1) The minimum diameter size of all structural members shall be measured at the member's midpoint, except that the minimum diameter size of posts shall be measured at the smaller end. For structure sizes not specifically shown in the tables, the requirements in the next larger width size shall be applicable.
- (2) The specifications for structural members were estimated based on no wind loads. Hale shall be constructed to allow all thatching materials to separate from the structure prior to adding significant loads.
- (3) The mix formula for mortar specified in these rules shall be one part portland cement, four parts clean sand, and sufficient fresh water to make the mixture workable.
- (4) Every hale, except Hale Noa, shall have at least two sides completely open.
- (5) Lashing and thatching methods shall comply with illustrations found in "Arts and Crafts of Hawai'i" or "The Hawaiian Grass House in Bishop Museum."

X402 Allowable designs. Hale shall be designed and constructed in accordance with the requirements in Sections 402.1 through 402.4.

X402.1 Hale Halawai. Each end of the Hale Halawai may be open or thatched. The ends may also be constructed with a thatched roof hip as an alternate design. Hale Halawai shall be designed in accordance with the following schematics and illustrations. Structural components for Hale Halawai shall meet the size and spacing requirements in Table X402.1(a). Foundations for Hale Halawai shall be designed in accordance with Table X402.1(b).

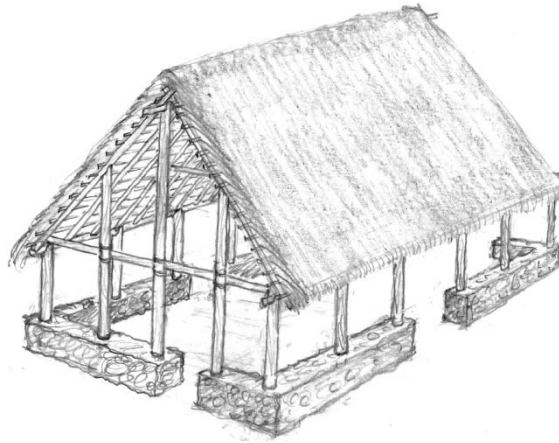

HALE HALAWAI
Open End Style

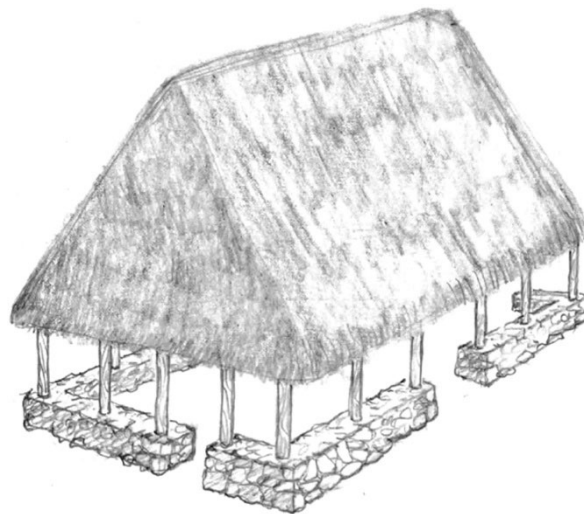

HALE HALAWAI
Thatched End Style

FRAMING SCHEMATIC

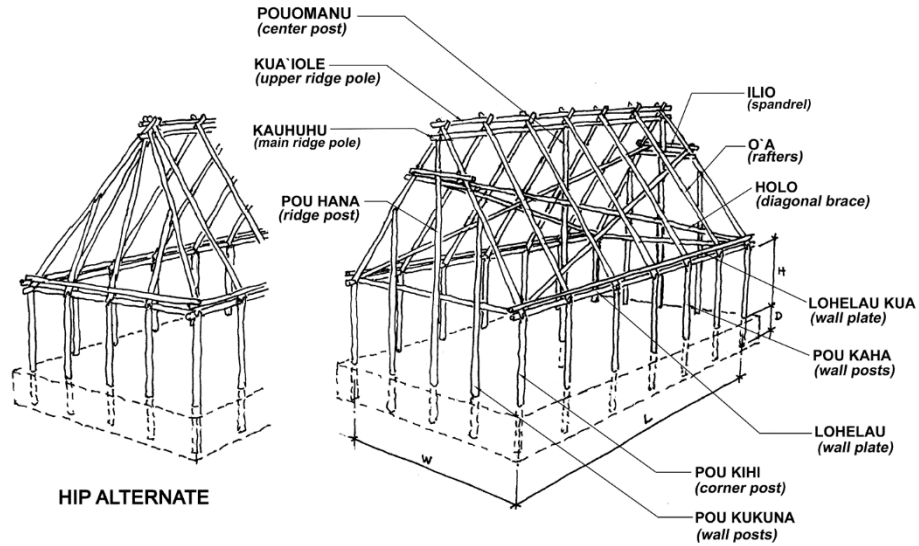

**TABLE X402.1(a)
SIZE AND SPACING REQUIREMENTS
FOR STRUCTURAL COMPONENTS USED IN HALE HALAWAI**

| Size W x L x H | Pou Kihl | Pou Kukuna & Pou Kaha | Pou Hana | Pouomanu | O'a | Kuaiole & Holo | Kauhuhu | Lohelau | Maximum post spacing (feet) | Maximum rafter spacing (feet) |
|----------------------|---------------------------|-----------------------------|----------|----------|-----|----------------------|---------|---------|--------------------------------------|--|
| | Minimum Diameter (inches) | | | | | | | | | |
| 12' x 20' x 7' | 4 | 3½ | 4 | 4 | 3½ | 2½ | 3 | 3 | 5 | 3 |
| 14' x 24' x 7' | 4 | 4 | 4½ | 4½ | 3½ | 2½ | 3 | 3½ | 5 | 3 |
| 24' x 30' x 7' | 5 | 4½ | 4½ | 4½ | 4 | 2½ | 3 | 3½ | 5 | 3 |
| 25' x 50' x 7' | 5½ | 5 | 5½ | 5½ | 4 | 2½ | 3 | 3½ | 5 | 3 |
| 30' x 60' x 7' | 6 | 5½ | 6 | 6 | 4½ | 2½ | 3 | 4 | 5 | 3 |

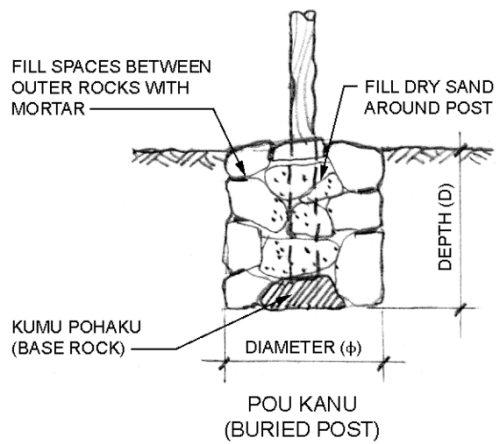
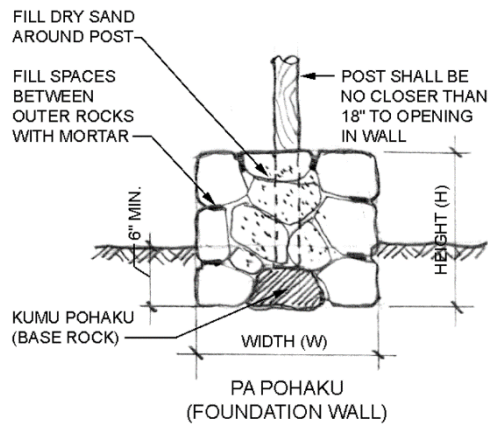
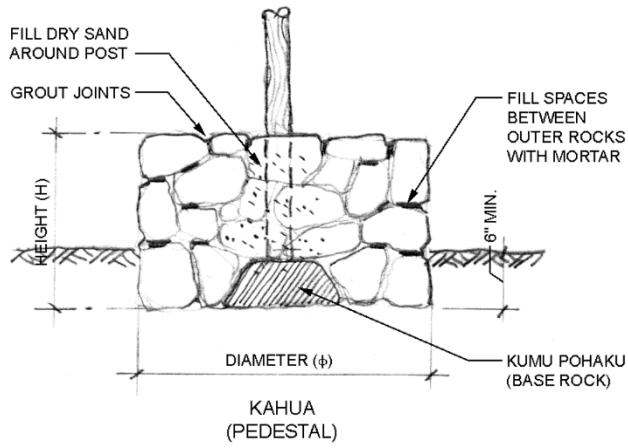
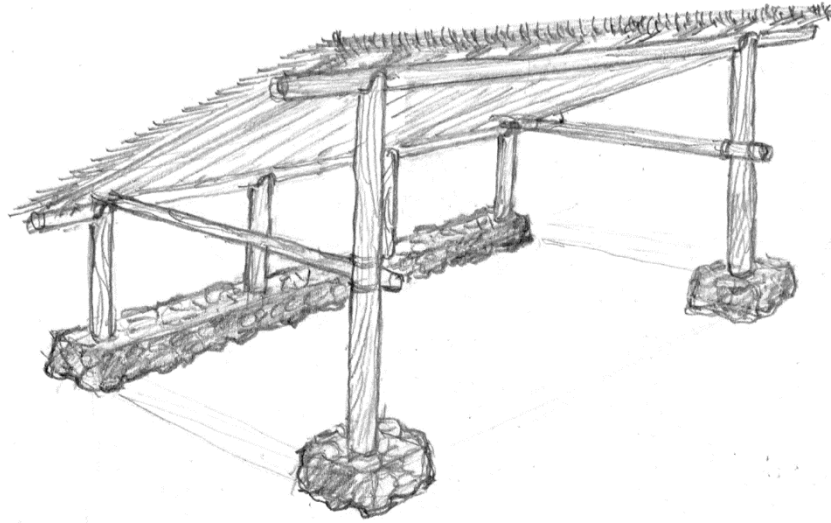

TABLE X402.1(b)
FOUNDATION DESIGN FOR HALE HALAWAI

| Size (W x L x H) | Foundation Type | | |
|---------------------|-------------------------------|---|---------------------------------|
| | Kahua Diameter x Height | Pa Pohaku Width x Height x Length | Pou Kanu Diameter x Depth |
| 12' x 20' x 7' | 3'6"φ x 24"H | 2'6"W x 2'8"H x 4'0"L | 30"φ x 2'8"D |
| 14' x 24' x 7' | 3'8"φ x 24"H | 2'6"W x 2'8"H x 4'0"L | 30"φ x 2'9"D |
| 24' x 30' x 7' | 4'0"φ x 30"H | 3'0"W x 3'0"H x 4'0"L | 36"φ x 3'0"D |
| 25' x 50' x 7' | 4'0"φ x 30"H | 3'0"W x 3'0"H x 4'0"L | 36"φ x 3'0"D |
| 30' x 60' x 7' | 4'0"φ x 30"H | 3'0"W x 3'3"H x 4'0"L | 36"φ x 3'3"D |

X402.2 Hale Ku'ai. Hale Ku'ai shall be designed in accordance with the following schematics and illustrations. Structural components for Hale Ku'ai shall meet the size and spacing requirements in Table X402.2(a). Foundations for Hale Ku'ai shall be designed in accordance with Table X402.2(b).



**HALE KU'AI
SHED STYLE**

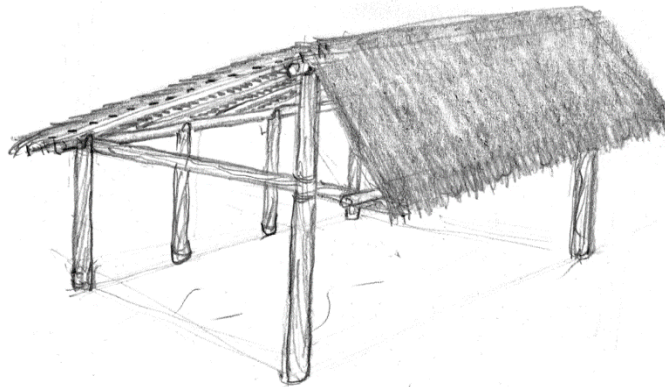

**HALE KU'AI
GABLE STYLE**

FRAMING SCHEMATIC 1

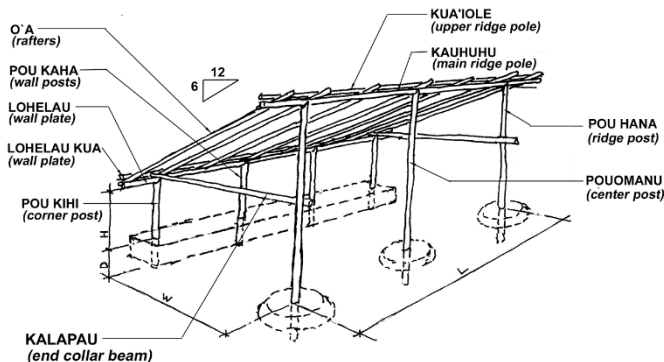

FRAMING SCHEMATIC 2

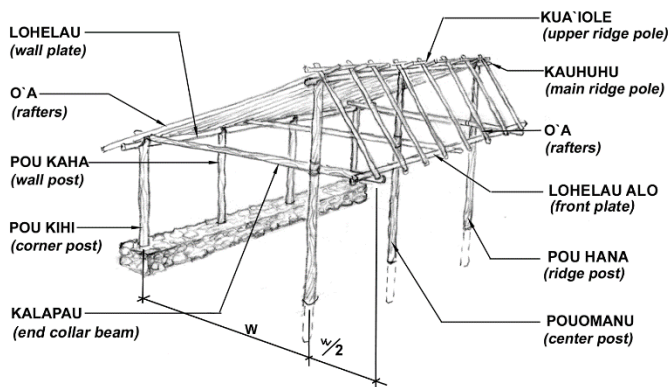

**TABLE X402.2(a)
SIZE AND SPACING REQUIREMENTS
FOR STRUCTURAL COMPONENTS USED IN HALE KU'AI**

| Size (W x L x H) | Pou Kih ^a | Pou Kaha ^a | Pou Hana ^b | Pouo Manu ^b | O'a | Kuaiole & Holo | Kauhuhu | Lohelau | Maximum rafter spacing (feet) |
|---------------------------|-------------------------|--------------------------|--------------------------|---------------------------|-----|----------------------|---------|---------|--|
| Minimum Diameter (inches) | | | | | | | | | |
| 5' x 10' x 5' | 4 | 3 | 3 | 4 | 3 | 2 | 3 | 2 | 4 |
| 9' x 12' x 5' | 4 | 3 | 3 | 4 | 3 | 2 | 3½ | 2 | 4 |
| 12' x 16' x 5' | 4½ | 3½ | 4 | 4 | 3½ | 2 | 4 | 2½ | 4 |
| 14' x 20' x 5' | 4½ | 3½ | 4 | 4 | 3½ | 2½ | 4½ | 2½ | 4 |

- a. The maximum post spacing for pou kih and pou kaha is five feet.
- b. The maximum post spacing for pou hana and pouomanu is twelve feet.

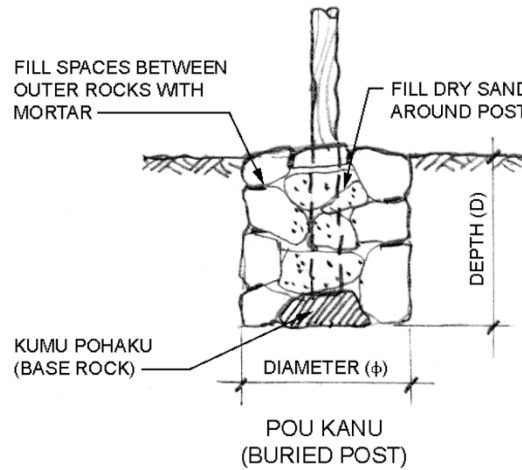
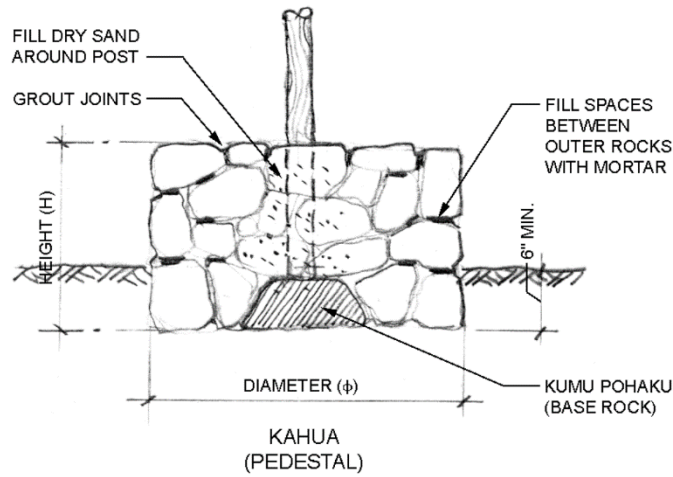
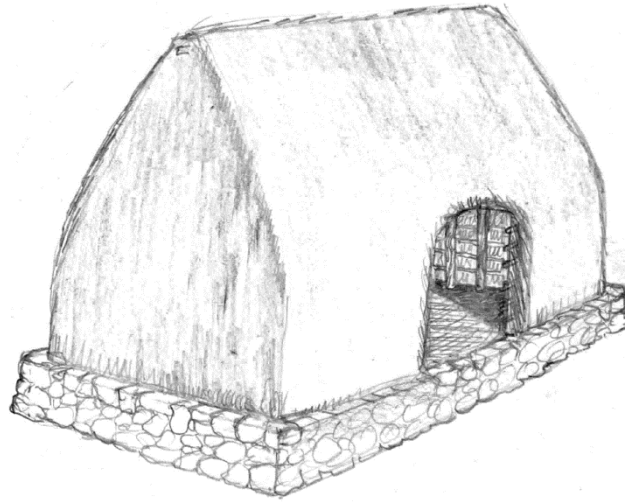

TABLE X402.2(b)
FOUNDATION DESIGN FOR HALE KU'AI

| Size (W x L x H) | Foundation Type | | |
|---------------------|-------------------------------|---|---------------------------------|
| | Kahua Diameter x Height | Pa Pohaku Width x Height x Length | Pou Kanu Diameter x Depth |
| 5' x 10' x 5' | 3'0"φ x 24"H | 2'6"W x 2'0"H x 4'0"L | 30"φ x 2'6"D |
| 9' x 12' x 5' | 3'4"φ x 24"H | 2'6"W x 2'0"H x 4'0"L | 30"φ x 2'6"D |
| 12' x 16' x 5' | 3'6"φ x 24"H | 2'6"W x 2'8"H x 4'0"L | 30"φ x 2'8"D |
| 14' x 20' x 5' | 3'8"φ x 24"H | 2'6"W x 2'8"H x 4'0"L | 30"φ x 2'9"D |

402.3 Hale Noa. Hale Noa shall have at least two openings. One opening shall be at least 3 feet wide and 5 feet high, and the other opening shall be at least 2 feet wide and 3 feet high. Hale Noa shall be designed in accordance with the following schematics and illustrations. Structural components for Hale Noa shall meet the size and spacing requirements in Table X402.3(a). Foundations for Hale Noa shall be designed in accordance with Table X402.3(b).



HALE NOA

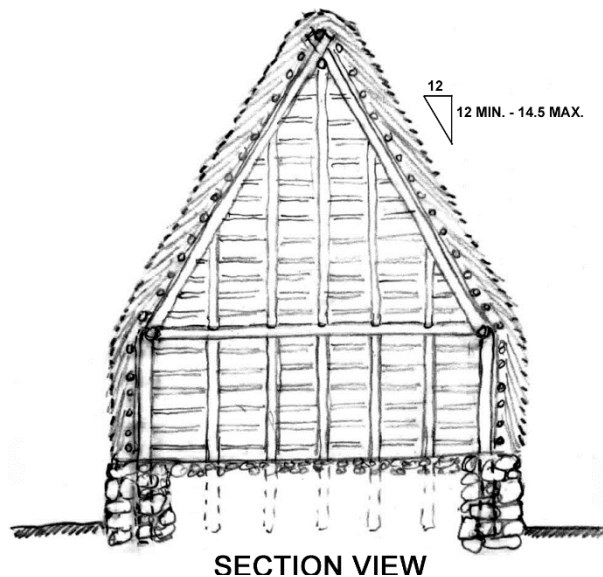

SECTION VIEW

FRAMING SCHEMATIC

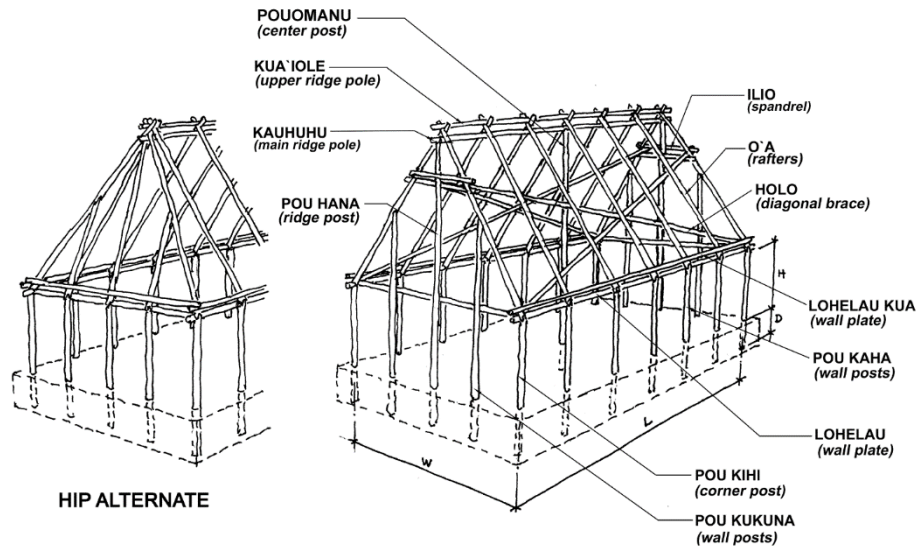
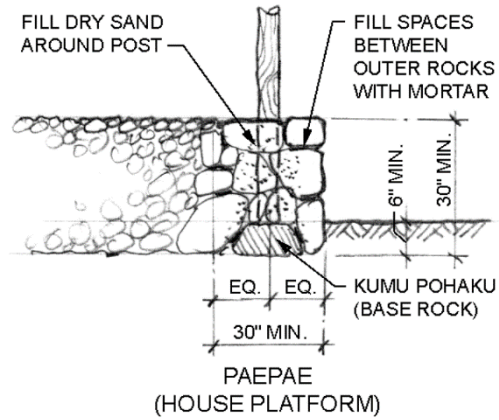
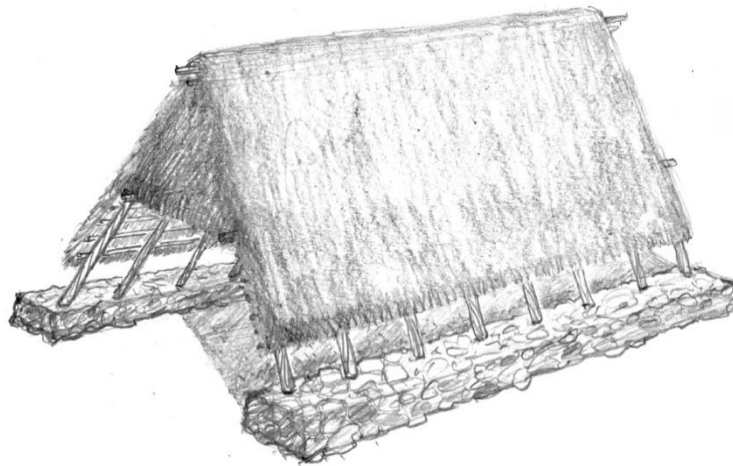

TABLE X402.3(a)
SIZE AND SPACING REQUIREMENTS
FOR STRUCTURAL COMPONENTS USED IN HALE NOA

| Size W x L x H | Pou KihU | Pou Kukuna & Pou Kaha | Pou Hana | Pouomanu | O'a | Kuaiole & Holo | Kauhuhu | Lohelau | Maximum post spacing (feet) | Maximum rafter spacing (feet) |
|-------------------|---------------------------|-----------------------|----------|----------|-----|----------------|---------|---------|-----------------------------|-------------------------------|
| | Minimum Diameter (inches) | | | | | | | | | |
| 9' x 12' x 7' | 3½ | 3 | 4 | 3 | 3 | 2½ | 3½ | 2½ | 6 | 4 |
| 12' x 20' x 7' | 4 | 4½ | 4 | 3 | 3½ | 2½ | 3½ | 2½ | 6 | 4 |
| 4' x 24' x 7' | 5½ | 4½ | 4 | 3 | 3½ | 2½ | 3½ | 3 | 6 | 4 |



402.4 Hale Wa'a. Hale Wa'a shall be designed in accordance with the following schematics and illustrations. Structural components for Hale Wa'a shall meet the size and spacing requirements in Table X402.4.



HALE WA'A

FRAMING SCHEMATIC

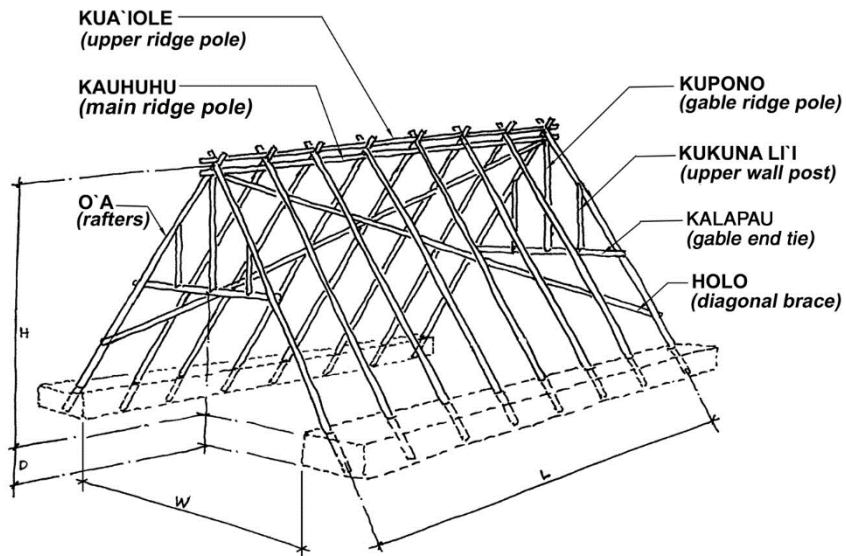

**TABLE X402.4
SIZE AND SPACING REQUIREMENTS
FOR STRUCTURAL COMPONENTS USED IN HALE WA'A**

| Size (W x L) | O'a | Kuaiole & Holo | Kauhuhu | Spacing between Rafters | Minimum ridge Height (H) |
|-----------------|-----|----------------------|---------|-------------------------------|--------------------------------|
| 20' x 60' | 4" | 3" | 4" | 4' to 5' | 22½' |
| 25' x 60' | 5" | 3" | 4" | 4' to 5' | 27½' |
| 30' X 60' | 5½" | 3" | 4" | 4' to 5' | 27½' |

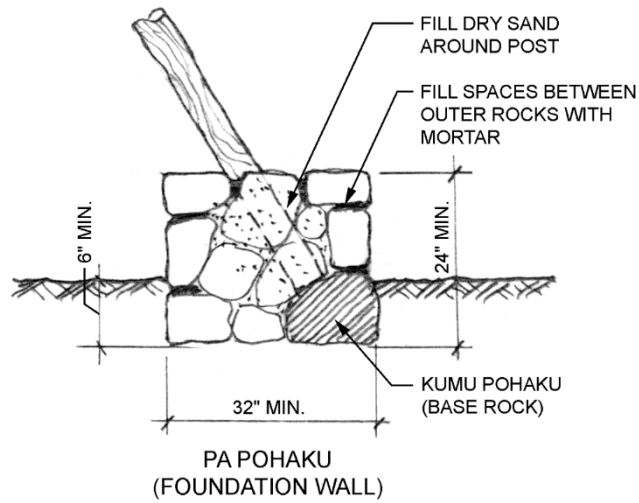

(2020, ord 20-61, sec 3.)

Section 5A-3-27. Repealed.

(2020, ord 20-61, sec 3; rep 2021, ord 21-61, sec 19.)

Article 4. Building Work Within Special Flood Hazard Areas.**Section 5A-4-1. General applicability.**

- (a) The provisions of this article shall apply to new construction or the renovation and major alteration, addition, or reinstallation of any existing buildings or structures, within a special flood hazard area as identified by chapter 27, Hawai'i County Code. All construction work shall comply with chapter 16 of the International Building Code, and chapter 27, Floodplain Management.
- (b) The provisions of this article shall not apply to the following:
- (1) Any building or structure exempted from chapter 27;
 - (2) Any building or structure which has been granted a flood control variance pursuant to article 5, chapter 27; or
 - (3) Any building or structure lawfully existing prior to November 8, 1993, subject to the provisions of chapter 27.

(2020, ord 20-61, sec 3.)

Section 5A-4-2. Definitions.

As used in this article, unless it is apparent from the context that a different meaning is intended:

“Base flood elevation” means the water surface elevation of the base flood.

“Flood or flooding” means:

- (1) A general and temporary condition of partial or complete inundation of normally dry land areas from:
 - (A) The overflow of inland or tidal waters;
 - (B) The unusual and rapid accumulation or runoff of surface waters from any source; or
 - (C) Mudslides (i.e., mudflows) which are approximately caused by flooding as defined in paragraph (1)(B) of this definition and are akin to a river of liquid and flowing mud on the surfaces of normally dry land areas, as when earth is carried by a current of water and deposited along the path of the current; or
- (2) The collapse or subsidence of land along the shore of a lake or other body of water as a result of erosion or undermining caused by waves or currents of water exceeding anticipated cyclical levels or suddenly caused by an unusually high water level in a natural body of water, accompanied by a severe storm, or by an unanticipated force of nature, such as flash flood or an abnormal tidal surge, or by some similarly unusual and unforeseeable event which results in flooding as defined in paragraph (1)(A) of this definition.

“Special flood hazard area” means an area having special flood or flood-related erosion hazards, and shown on the Flood Insurance Rate Maps as Zones A, AO, AE, A99, AH, VE, or V.

“Water-tight” when referring to construction below the inundation level, means constructed to exclude moisture and withstand the hydraulic pressure resulting from the anticipated depth of inundation.

(2020, ord 20-61, sec 3.)

Section 5A-4-3. General requirements.

Contractor will provide a certified flood zone elevation mark on jobsite for flood zone elevation reference point.

(2020, ord 20-61, sec 3.)

This page intentionally left blank.